

# **ADSP-21160 EZ-KIT Lite® Evaluation System Manual**

Revision 5.0, July 2007

Part Number  
82-000513-01

Analog Devices, Inc.  
One Technology Way  
Norwood, Mass. 02062-9106



## **Copyright Information**

©2007 Analog Devices, Inc., ALL RIGHTS RESERVED. This document may not be reproduced in any form without prior, express written consent from Analog Devices, Inc.

Printed in the USA.

## **Limited Warranty**

The EZ-KIT Lite evaluation system is warranted against defects in materials and workmanship for a period of one year from the date of purchase from Analog Devices or from an authorized dealer.

## **Disclaimer**

Analog Devices, Inc. reserves the right to change this product without prior notice. Information furnished by Analog Devices is believed to be accurate and reliable. However, no responsibility is assumed by Analog Devices for its use; nor for any infringement of patents or other rights of third parties which may result from its use. No license is granted by implication or otherwise under the patent rights of Analog Devices, Inc.

## **Trademark and Service Mark Notice**

The Analog Devices icon bar and logo, VisualDSP++, the VisualDSP++ logo, SHARC, SHARC logo, CROSSCORE, the CROSSCORE logo, and EZ-KIT Lite are registered trademarks of Analog Devices, Inc.

All other brand and product names are trademarks or service marks of their respective owners.

## Regulatory Compliance

The ADSP-21160 EZ-KIT Lite is designed to be used solely in a laboratory environment. The board is not intended for use as a consumer end product or as a portion of a consumer end product. The board is an open system design which does not include a shielded enclosure and therefore may cause interference to other electrical devices in close proximity. This board should not be used in or near any medical equipment or RF devices.

The ADSP-21160 EZ-KIT Lite has been certified to comply with the essential requirements of the European EMC directive 89/336/EEC amended by 93/68/EEC and therefore carries the “CE” mark.

The ADSP-21160 EZ-KIT Lite has been appended to Analog Devices, Inc. Technical Construction File (TCF) referenced ‘DSPTOOLS1’ dated December 21, 1997 and was awarded CE Certification by an appointed European Competent Body as listed below.

Technical Certificate No: Z600ANA1.004

Issued by: Technology International (Europe) Limited  
60 Shrivenham Hundred Business Park  
Shrivenham, Swindon, SN6 8TY, UK



The EZ-KIT Lite evaluation system contains ESD (electrostatic discharge) sensitive devices. Electrostatic charges readily accumulate on the human body and equipment and can discharge without detection. Permanent damage may occur on devices subjected to high-energy discharges. Proper ESD precautions are recommended to avoid performance degradation or loss of functionality. Store unused EZ-KIT Lite boards in the protective shipping package.





# CONTENTS

## PREFACE

Purpose of This Manual .....	xii
Intended Audience .....	xii
Manual Contents .....	xiii
What's New in This Manual .....	xiii
Technical or Customer Support .....	xiv
Supported Processors .....	xiv
Product Information .....	xv
MyAnalog.com .....	xv
Processor Product Information .....	xv
Related Documents .....	xvi
Online Technical Documentation .....	xvii
Accessing Documentation From VisualDSP++ .....	xviii
Accessing Documentation From Windows .....	xviii
Accessing Documentation From Web .....	xix
Printed Manuals .....	xix
VisualDSP++ Documentation Set .....	xix
Hardware Tools Manuals .....	xix
Processor Manuals .....	xx

# CONTENTS

Data Sheets .....	xx
Notation Conventions .....	xxi

## USING ADSP-21160 EZ-KIT LITE

Package Contents .....	1-2
Default Configuration .....	1-3
Installation and Session Startup .....	1-5
Evaluation License Restrictions .....	1-7
Memory Map .....	1-7
Flag Pins .....	1-9
Interrupt Pins .....	1-9
Example Programs .....	1-10
Flash Programmer Utility .....	1-10

## ADSP-21160 EZ-KIT LITE HARDWARE

System Architecture .....	2-2
External Port .....	2-3
SPORT0 Audio Interface .....	2-4
Expansion Interface .....	2-4
JTAG Emulation Port .....	2-5
Jumper and Switches .....	2-6
Audio Input Selection Jumper (JP1) .....	2-6
Boot Mode Select Switch (SW1) .....	2-7
LEDs and Push Buttons .....	2-8
Reset LED (LED7) .....	2-8

Flag LEDs (LED2–4) .....	2-9
USB Monitor LED (ZLED3) .....	2-9
Power LED (LED6) .....	2-9
Board Reset Push Button (SW2) .....	2-10
Interrupt Push Buttons (SW3–5) .....	2-10
Connectors .....	2-11
Expansion Connectors (P1–3) .....	2-12
Power Connector (P4) .....	2-12
Link Port Connectors (P5 and P6) .....	2-13
USB Connector (ZJ1) .....	2-13
JTAG Connector (ZP4) .....	2-14
Audio Connectors (J4 and J5) .....	2-14
SPORT0 Connector (P11) .....	2-15
Specifications .....	2-16
Power Supply .....	2-16
Board Current Measurements .....	2-16

## **ADSP-21160 EZ-KIT LITE BILL OF MATERIALS**

## **ADSP-21160 EZ-KIT LITE SCHEMATIC**

Title Page .....	B-1
ADSP-21160 Processor .....	B-2
Memory .....	B-3
Audio Codec .....	B-4
Push Buttons and LEDs .....	B-5

# CONTENTS

Connectors .....	B-6
Power .....	B-7
Bypass Caps .....	B-8

# INDEX



# PREFACE

Thank you for purchasing the ADSP-21160 EZ-KIT Lite<sup>®</sup>, Analog Devices, Inc. evaluation system for SHARC<sup>®</sup> digital signal processors (DSPs).

SHARC processors are based on a 32-bit super Harvard architecture that includes a unique memory architecture comprised of two large on-chip, dual-ported SRAM blocks coupled with a sophisticated IO processor, which gives a SHARC processor the bandwidth for sustained high-speed computations. SHARC processors represent today's de facto standard for floating-point processor targeted for premium audio applications.

The evaluation system is designed to be used in conjunction with the VisualDSP++<sup>®</sup> development environment to test the capabilities of ADSP-21160 SHARC processors. The VisualDSP++ development environment gives you the ability to perform advanced application code development and debug, such as:

- Create, compile, assemble, and link application programs written in C++, C, and ADSP-21160 assembly
- Load, run, step, halt, and set breakpoints in application programs
- Read and write data and program memory
- Read and write core and peripheral registers
- Plot memory

Access to the ADSP-21160 processor from a personal computer (PC) is achieved through a USB port or an optional JTAG emulator. The USB interface provides unrestricted access to the ADSP-21160 processor and the evaluation board peripherals. Analog Devices JTAG emulators offer faster communication between the host PC and target hardware. Analog Devices carries a wide range of in-circuit emulation products. To learn more about Analog Devices emulators and processor development tools, go to <http://www.analog.com/dsp/tools/>.

The ADSP-21160 EZ-KIT Lite provides example programs to demonstrate the capabilities of the evaluation board.

 The ADSP-21160 EZ-KIT Lite installation is part of the VisualDSP++ installation. The EZ-KIT Lite is a licensed product that offers an unrestricted evaluation license for the first 90 days. For details about evaluation license restrictions after the 90 days, refer to “[Evaluation License Restrictions](#)” on page 1-7.

ADSP-21160 EZ-KIT Lite provides example programs to demonstrate the capabilities of the evaluation board.

The board features:

- Analog Devices ADSP-21160 processor
  - ADSP-21160M processor:
    - ✓ 2.5V core voltage
    - ✓ 80 MHz core clock speed
  - Switch-configurable boot mode
- Analog Devices AD1881A 48 kHz AC'97 SoundMAX<sup>®</sup> codec
  - ✓ Jumper selectable line-in or mic-in 3.5 mm stereo jack
  - ✓ Line-out 3.5 mm stereo jack
- USB debugging interface

- SBSRAM
  - ✓ 512 Kb (64K x 32-bits x 2-chips)
- Flash memory
  - ✓ 512 Kb (512K x 8-bits)
- Interface connectors
  - ✓ 14-pin emulator connector for JTAG interface
  - ✓ SPORT0 connectors
  - ✓ Two link port connectors
  - ✓ Expansion interface connectors (not populated)
- General-purpose IO
  - ✓ 3 push buttons connected to processor IRQs
  - ✓ 3 LEDs connected to processor flags

The EZ-KIT Lite board has two types of external memory: flash memory and SBSRAM. The flash memory can store user-specified boot code. By configuring the boot mode switch (SW1) and programming the flash memory, the board can run as a stand-alone unit. For information about the external memory, see [“Memory Map” on page 1-7](#).

SPORT0 is interfaced to an audio codec, facilitating development of audio signal processing applications. SPORT0 also connects to an off-board connector for communication with other serial devices. For information about SPORT0, see [“SPORT0 Audio Interface” on page 2-4](#).

Additionally, the EZ-KIT Lite board provides access to most of the processor’s peripheral ports on populated expansion interface connectors. For information about the expansion interface, see [“External Port” on page 2-3](#).

# Purpose of This Manual

The *ADSP-21160 EZ-KIT Lite Evaluation System Manual* provides instructions for installing the product hardware (board) and describes the operation and configuration of the board components. The product software installation is detailed in the *VisualDSP++ Installation Quick Reference Card*. The manual provides guidelines for running your own code on the ADSP-21160 EZ-KIT Lite. Finally, a schematic and a bill of materials are provided as a reference for future designs.

## Intended Audience

The primary audience for this manual is a programmer who is familiar with Analog Devices processors. This manual assumes that the audience has a working knowledge of the appropriate processor architecture and instruction set. Programmers who are unfamiliar with Analog Devices processors can use this manual but should supplement it with other texts (such as the *ADSP-21160 SHARC Processor Hardware Reference* and *ADSP-21160 SHARC Processor Instruction Set Reference*) that describe your target architecture.

Programmers who are unfamiliar with VisualDSP++ should refer to the VisualDSP++ online Help and user's or getting started guides. For the locations of these documents, see [“Related Documents”](#) on page -xvi.

# Manual Contents

The manual consists of:

- Chapter 1, “Using ADSP-21160 EZ-KIT Lite” on page 1-1  
Provides information on the EZ-KIT Lite from a programmer’s perspective and provides a simplified memory map.
- Chapter 2, “ADSP-21160 EZ-KIT Lite Hardware” on page 2-1  
Provides information on the hardware aspects of the evaluation system.
- Appendix A, “ADSP-21160 EZ-KIT Lite Bill Of Materials” on page A-1  
Provides a list of components used to manufacture the EZ-KIT Lite board.
- Appendix B, “ADSP-21160 EZ-KIT Lite Schematic” on page B-1  
Provides the resources to allow EZ-KIT Lite board-level debugging or to use as a reference design.



Appendix B now is part of the online Help. The PDF version of the *ADSP-21160 EZ-KIT Lite Evaluation System Manual* is located in the Docs\EZ-KIT Lite Manuals folder on the installation CD. Alternatively, the book can be found at the Analog Devices Web site, [www.analog.com/processors](http://www.analog.com/processors).

## What’s New in This Manual

This edition of the *ADSP-21160 EZ-KIT Lite Evaluation System Manual* documents ADSP-21160 EZ-KIT Lite compliance with the RoHS and WEEE directives.

# Technical or Customer Support

You can reach Analog Devices, Inc. Customer Support in the following ways:

- Visit the Embedded Processing and DSP products Web site at <http://www.analog.com/processors/technicalSupport>
- E-mail tools questions to [processor.tools.support@analog.com](mailto:processor.tools.support@analog.com)
- E-mail processor questions to [processor.support@analog.com](mailto:processor.support@analog.com) (World wide support)  
[processor.europe@analog.com](mailto:processor.europe@analog.com) (Europe support)  
[processor.china@analog.com](mailto:processor.china@analog.com) (China support)
- Phone questions to **1-800-ANALOGD**
- Contact your Analog Devices, Inc. local sales office or authorized distributor
- Send questions by mail to:  
Analog Devices, Inc.  
One Technology Way  
P.O. Box 9106  
Norwood, MA 02062-9106  
USA

## Supported Processors

This EZ-KIT Lite evaluation system supports Analog Devices ADSP-21160 SHARC processors.

## Product Information

You can obtain product information from the Analog Devices Web site, from the product CD-ROM, or from printed publications (manuals).

Analog Devices is online at [www.analog.com](http://www.analog.com). Our Web site provides information about a broad range of products—analog integrated circuits, amplifiers, converters, and digital signal processors.

## MyAnalog.com

MyAnalog.com is a free feature of the Analog Devices Web site that allows customization of a Web page to display only the latest information on products you are interested in. You can choose to receive weekly e-mail notifications containing updates to the Web pages that meet your interests, including documentation errata against all manuals. You can also choose to receive weekly e-mail notifications containing updates to the Web pages that meet your interests. MyAnalog.com provides access to books, application notes, data sheets, code examples, and more.

### Registration:

Visit [www.analog.com](http://www.analog.com) to sign up. Click **Register** to use MyAnalog.com. Registration takes about five minutes and serves as means for you to select the information you want to receive.

If you are already a registered user, just log on. Your user name is your email address.

## Processor Product Information

For information on embedded processors and DSPs, visit our Web site at [www.analog.com/processors](http://www.analog.com/processors), which provides access to technical publications, data sheets, application notes, product overviews, and product announcements.

## Product Information

You may also obtain additional information about Analog Devices and its products in any of the following ways.

- E-mail questions or requests for information to  
[processor.support@analog.com](mailto:processor.support@analog.com) (World wide support)  
[processor.europe@analog.com](mailto:processor.europe@analog.com) (Europe support)  
[processor.china@analog.com](mailto:processor.china@analog.com) (China support)
- Fax questions or requests for information to  
1-781-461-3010 (North America)  
+49-89-76903-157 (Europe)

## Related Documents

For information on product related development software, see the following publications.

Table 1. Related Processor Publications

Title	Description
<i>ADSP-21160M SHARC DSP Data Sheet</i> <i>ADSP-21160N DSP Microcomputer Data Sheet</i>	General functional description, pinout, and timing
<i>ADSP-21160 SHARC Processor Hardware Reference</i>	Description of internal processor architecture, registers, and all peripheral functions
<i>ADSP-21160 SHARC Processor Instruction Set Reference</i>	Description of all allowed processor assembly instructions

Table 2. Related VisualDSP++ Publications

Title	Description
<i>VisualDSP++ User's Guide</i>	Description of VisualDSP++ features and usage
<i>VisualDSP++ Assembler and Preprocessor Manual</i>	Description of the assembler function and commands
<i>VisualDSP++ C/C++ Compiler Manual for SHARC Processors</i>	Description of the compiler function and commands for SHARC processors



Table 2. Related VisualDSP++ Publications (Cont'd)

Title	Description
<i>VisualDSP++ Run-Time Library Manual for SHARC Processors</i>	Description of the run-time library functions for SHARC processors
<i>VisualDSP++ Linker and Utilities Manual</i>	Description of the linker function and commands
<i>VisualDSP++ Loader and Utilities Manual</i>	Description of the loader function and commands

 If you plan to use the EZ-KIT Lite board in conjunction with a JTAG emulator, also refer to the documentation that accompanies the emulator.

All documentation is available online. Most documentation is available in printed form.

Visit the Technical Library Web site to access all processor and tools manuals and data sheets:

<http://www.analog.com/processors/technicalSupport/technicalLibrary/>.

## Online Technical Documentation

Online documentation comprises the VisualDSP++ Help system, software tools manuals, hardware tools manuals, processor manuals, the Dinkum Abridged C++ library, and Flexible License Manager (FlexLM) network license manager software documentation. You can easily search across the entire VisualDSP++ documentation set for any topic of interest. For easy printing, supplementary .pdf files of most manuals are provided in the Docs folder on the VisualDSP++ installation CD.

Each documentation file type is described as follows.

## Product Information

File	Description
.chm	Help system files and manuals in Help format
.htm or .html	Dinkum Abridged C++ library and FlexLM network license manager software documentation. Viewing and printing the .html files requires a browser, such as Internet Explorer 6.0 (or higher).
.pdf	VisualDSP++ and processor manuals in Portable Documentation Format (PDF). Viewing and printing the .pdf files requires a PDF reader, such as Adobe Acrobat Reader (4.0 or higher).

If documentation is not installed on your system as part of the software installation, you can add it from the VisualDSP++ CD at any time by running the Tools installation. Access the online documentation from the VisualDSP++ environment, Windows<sup>®</sup> Explorer, or the Analog Devices Web site.

### Accessing Documentation From VisualDSP++

To view VisualDSP++ Help, click on the **Help** menu item or go to the Windows task bar and navigate to the VisualDSP++ documentation via the **Start** menu.

To view ADSP-21160 EZ-KIT Lite Help, which is part of the VisualDSP++ Help system, use the **Contents** or **Search** tab of the Help window.

### Accessing Documentation From Windows

In addition to any shortcuts you may have constructed, there are many ways to open VisualDSP++ online Help or the supplementary documentation from Windows.

Help system files (.chm) are located in the `Help` folder, and .pdf files are located in the `Docs` folder of your VisualDSP++ installation CD-ROM. The `Docs` folder also contains the Dinkum Abridged C++ library and the FlexLM network license manager software documentation.

Your software installation kit includes online Help as part of the Windows<sup>®</sup> interface. These help files provide information about VisualDSP++ and the ADSP-21160 EZ-KIT Lite evaluation system.

### Accessing Documentation From Web

Download manuals at the following Web site:

<http://www.analog.com/processors/technicalSupport/technicalLibrary/>.

Select a processor family and book title. Download archive (.zip) files, one for each manual. Use any archive management software, such as Win-Zip, to decompress downloaded files.

### Printed Manuals

For general questions regarding literature ordering, call the Literature Center at 1-800-ANALOGD (1-800-262-5643) and follow the prompts.

### VisualDSP++ Documentation Set

To purchase VisualDSP++ manuals, call 1-603-883-2430. The manuals may be purchased only as a kit.

If you do not have an account with Analog Devices, you are referred to Analog Devices distributors. For information on our distributors, log onto <http://www.analog.com/salesdir/continent.asp>.

### Hardware Tools Manuals

To purchase EZ-KIT Lite and in-circuit emulator (ICE) manuals, call 1-603-883-2430. The manuals may be ordered by title or by product number located on the back cover of each manual.

## Product Information

### Processor Manuals

Hardware reference and instruction set reference manuals may be ordered through the Literature Center at **1-800-ANALOGD (1-800-262-5643)**, or downloaded from the Analog Devices Web site. Manuals may be ordered by title or by product number located on the back cover of each manual.



### Data Sheets

All data sheets (preliminary and production) may be downloaded from the Analog Devices Web site. Only production (final) data sheets (Rev. 0, A, B, C, and so on) can be obtained from the Literature Center at **1-800-ANALOGD (1-800-262-5643)**; they also can be downloaded from the Web site.

To have a data sheet faxed to you, call the Analog Devices Faxback System at **1-800-446-6212**. Follow the prompts and a list of data sheet code numbers will be faxed to you. If the data sheet you want is not listed, check for it on the Web site.

## Notation Conventions

Text conventions used in this manual are identified and described as follows.

Example	Description
Close command (File menu)	Titles in reference sections indicate the location of an item within the VisualDSP++ environment's menu system (for example, the <b>Close</b> command appears on the <b>File</b> menu).
{this   that}	Alternative required items in syntax descriptions appear within curly brackets and separated by vertical bars; read the example as <i>this</i> or <i>that</i> . One or the other is required.
[this   that]	Optional items in syntax descriptions appear within brackets and separated by vertical bars; read the example as an optional <i>this</i> or <i>that</i> .
[this,...]	Optional item lists in syntax descriptions appear within brackets delimited by commas and terminated with an ellipsis; read the example as an optional comma-separated list of <i>this</i> .
.SECTION	Commands, directives, keywords, and feature names are in text with letter gothic font.
<i>filename</i>	Non-keyword placeholders appear in text with italic style format.
	<b>Note:</b> For correct operation, ... A Note provides supplementary information on a related topic. In the online version of this book, the word <b>Note</b> appears instead of this symbol.
	<b>Caution:</b> Incorrect device operation may result if ... <b>Caution:</b> Device damage may result if ... A Caution identifies conditions or inappropriate usage of the product that could lead to undesirable results or product damage. In the online version of this book, the word <b>Caution</b> appears instead of this symbol.
	<b>Warning:</b> Injury to device users may result if ... A Warning identifies conditions or inappropriate usage of the product that could lead to conditions that are potentially hazardous for the devices users. In the online version of this book, the word <b>Warning</b> appears instead of this symbol.

## Notation Conventions

 Additional conventions, which apply only to specific chapters, may appear throughout this document.

# 1 USING ADSP-21160 EZ-KIT LITE

This chapter provides specific information to assist you with development of programs for the ADSP-21160 EZ-KIT Lite evaluation system.

The information appears in the following sections.

- [“Package Contents” on page 1-2](#)  
Lists the items contained in the EZ-KIT Lite package.
- [“Default Configuration” on page 1-3](#)  
Shows the default configuration of the ADSP-21160 EZ-KIT Lite.
- [“Installation and Session Startup” on page 1-5](#)  
Instructs how to start a new or open an existing EZ-KIT Lite session using VisualDSP++.
- [“Evaluation License Restrictions” on page 1-7](#)  
Describes the restrictions of the VisualDSP++ license shipped with the EZ-KIT Lite.
- [“Memory Map” on page 1-7](#)  
Defines the memory map of the EZ-KIT Lite board.
- [“Flag Pins” on page 1-9](#)  
Describes the flag pins of the EZ-KIT Lite board.
- [“Interrupt Pins” on page 1-9](#)  
Describes the interrupt pins of the EZ-KIT Lite board.

## Package Contents

- [“Example Programs” on page 1-10](#)  
Provides information about example programs included in the ADSP-21160 EZ-KIT Lite.
- [“Flash Programmer Utility” on page 1-10](#)  
Provides information on the Flash Programmer utility included with the EZ-KIT Lite software.

For information on the graphical user interface, including the boot loading, target options, and other facilities of the EZ-KIT Lite system, refer to the online Help.

For detailed information on how to program the ADSP-21160 SHARC processor, refer to the documents referenced in [“Related Documents” on page xvi](#).

## Package Contents

Your ADSP-21160 EZ-KIT Lite evaluation system package contains the following items.

- ADSP-21160M EZ-KIT Lite board
- *VisualDSP++ Installation Quick Reference Card*
- CD containing:
  - ✓ VisualDSP++ software
  - ✓ ADSP-21160 EZ-KIT Lite debug software
  - ✓ USB driver files
  - ✓ Example programs
  - ✓ ADSP-21160 *EZ-KIT Lite Evaluation System Manual* (this document)



- Universal 7V DC power supply
- USB 2.0 cable

If any item is missing, contact the vendor where you purchased your EZ-KIT Lite or contact Analog Devices, Inc.

## Default Configuration

The EZ-KIT Lite evaluation system contains ESD (electrostatic discharge) sensitive devices. Electrostatic charges readily accumulate on the human body and equipment and can discharge without detection. Permanent damage may occur on devices subjected to high-energy discharges. Proper ESD precautions are recommended to avoid performance degradation or loss of functionality. Store unused EZ-KIT Lite boards in the protective shipping package.



The ADSP-21160 EZ-KIT Lite board is designed to run outside your personal computer as a stand-alone unit. You do not have to open your computer case.

To connect the EZ-KIT Lite board:

1. Remove the EZ-KIT Lite board from the package. Be careful when handling the board to avoid the discharge of static electricity, which may damage some components.
2. [Figure 1-1](#) shows the default jumper and switches settings, connector locations, and LEDs used in installation. Confirm that your board is set up in the default configuration before moving to the next step.

## Default Configuration

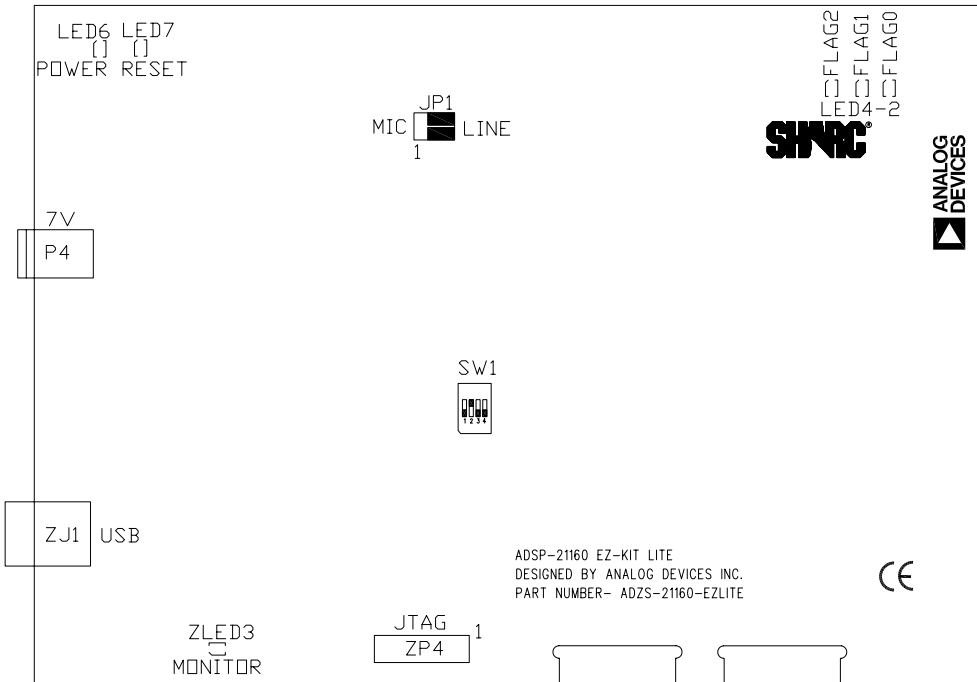



Figure 1-1. EZ-KIT Lite Hardware Setup

3. Plug the provided power supply into P4 on the EZ-KIT Lite board. Visually verify that the green power LED (LED6) is on. Also verify that the red reset LED (LED7) goes on for a moment and then goes off, and, finally, LED2 through LED4 are sequentially blinking.
4. Connect one end of the USB cable to an available full speed USB port on your PC and the other end to ZJ1 on the ADSP-21160 EZ-KIT Lite board.

## Installation and Session Startup

 For correct operation, install the software and hardware in the order presented in the *VisualDSP++ Installation Quick Reference Card*.

1. Verify that the yellow USB monitor LED (ZLED3, located near the USB connector) is lit. This signifies that the board is communicating properly with the host PC and is ready to run VisualDSP++.
2. If you are running VisualDSP++ for the first time, navigate to the VisualDSP++ environment via the **Start** → **Programs** menu. The main window appears. Note that VisualDSP++ does not connect to any session. Skip the rest of this step to step 3.

If you have run VisualDSP++ previously, the last opened session appears on the screen. You can override the default behavior and force VisualDSP++ to start a new session by pressing and holding down the **Ctrl** key while starting VisualDSP++. Do not release the **Ctrl** key until the **Session Wizard** appears on the screen. Go to step 4.

3. To connect to a new EZ-KIT Lite session, start **Session Wizard** by selecting one of the following.
  - From the **Session** menu, **New Session**.
  - From the **Session** menu, **Session List**. Then click **New Session** from the **Session List** dialog box.
  - From the **Session** menu, **Connect to Target**.
4. The **Select Processor** page of the wizard appears on the screen. Ensure **SHARC** is selected in **Processor family**. In **Choose a target processor**, select **ADSP-21160**. Click **Next**.
5. The **Select Connection Type** page of the wizard appears on the screen. Select **EZ-KIT Lite** and click **Next**.

## Installation and Session Startup

6. The **Select Platform** page of the wizard appears on the screen. Ensure that the selected platform is **ADSP-21160 EZ-KIT Lite via Debug Agent**. Specify your own **Session name** for your session or accept the default name.

The session name can be a string of any length; although, the box displays approximately 32 characters. The session name can include space characters. If you do not specify a session name, VisualDSP++ creates a session name by combining the name of the selected platform with the selected processor. The only way to change a session name later is to delete the session and to open a new session.

Click **Next**.

7. The **Finish** page of the wizard appears on the screen. The page displays your selections. Check the selections. If you are not satisfied, click **Back** to make changes; otherwise, click **Finish**. VisualDSP++ creates the new session and connects to the EZ-KIT Lite. Once connected, the main window's title is changed to include the session name set in step 6.



To disconnect from a session, click the disconnect button  or select **Session** → **Disconnect from Target**.

To delete a session, select **Session** → **Session List**. Select the session name from the list and click **Delete**. Click **OK**.

## Evaluation License Restrictions

The ADSP-21160 EZ-KIT Lite installation is part of the VisualDSP++ installation. The EZ-KIT Lite is a licensed product that offers an unrestricted evaluation license for the first 90 days. Once the initial unrestricted 90-day evaluation license expires:

- VisualDSP++ allows a connection to the ADSP-21160 EZ-KIT Lite via the USB Debug Agent interface only. Connections to simulators and emulation products are no longer allowed.
- The linker restricts a user's program to 21K words of internal memory for code space with no restrictions for data space.



The EZ-KIT Lite hardware must be connected and powered up to use VisualDSP++ with a valid temporary or permanent license.

Refer to the *VisualDSP++ Installation Quick Reference Card* for details.

## Memory Map

The ADSP-21160 processors includes internal SRAM for instruction storage or data storage. The configuration of internal SRAM is detailed in the *ADSP-21160 SHARC Processor Hardware Reference*.

The external port (EP) of the ADSP-21160 processor connects to the flash memory and SBSRAM. ADSP-21160 EZ-KIT Lite board contains 512 Kb x 8-bits of external flash memory. The flash memory connects to the processors's  $\sim$ MS0 and  $\sim$ BMS memory select pins.

SBSRAM is 512 Kb (64K x 32-bit x 2-chips). The SBSRAM memory connects to the  $\sim$ MS1 memory select pin. This memory is flow-through SBSRAM, capable of burst reads and writes. For information on how to set up burst moves, refer to the *ADSP-21160 SHARC Processor Hardware Reference*.

# Memory Map

The memory map in [Table 1-1](#) is dependant on the value of the MSIZE bits in the SYSCON register. The memory maps shows MSIZE set to 1100b.

Table 1-1. EZ-KIT Lite Evaluation Board Memory Map

	Start Address	End Address	Content
Internal memory	0x0000 0000	0x0000 FFFF	IOP registers
	0x0002 0000	0x0003 FFFF	Long word addressing
	0x0004 0000	0x0007 FFFF	Normal word addressing
	0x0008 0000	0x000F FFFF	Short word addressing
Multipro- cessor space	0x0010 0000	0x001F FFFF	ID = 001 (internal memory)
	0x0020 0000	0x002F FFFF	ID = 010 (internal memory)
	0x0030 0000	0x003F FFFF	ID = 011 (internal memory)
	0x0040 0000	0x004F FFFF	ID = 100 (internal memory)
	0x0050 0000	0x005F FFFF	ID = 101 (internal memory)
	0x0060 0000	0x006F FFFF	ID = 110 (internal memory)
	0x0070 0000	0x007F FFFF	ID = 111 (internal memory)
External memory	0x0080 0000	0x0087 FFFF	~MS0 and ~BMS (flash memory <sup>1</sup> )
	0x0280 0000	0x0281 FFFF	~MS1 (SBRAM)
	All other locations		Not used

<sup>1</sup> When viewing external memory with VisualDSP++, ensure that MSIZE is set to 0xC.

## Flag Pins

The ADSP-21160 processor holds four general-purpose programmable flag pins. The flag pins can be used as inputs or output depending on how they are configured in the `MODE2` system register. The state of a flag can be written to and read from the `FLAGS` system registers. When the flag pins are input, their current state can be found by reading the `FLAGS` system register. Flag pins set as outputs are driven to the value written to the `FLAGS` system register.

The locations of the signals can be found in “[ADSP-21160 EZ-KIT Lite Schematic](#)” on page B-1. The flag pins are summarized in Table 1-2. For more information on flags, refer to the *ADSP-21160 SHARC Processor Hardware Reference*

Table 1-2. Flag Pin Summary

Flag <sup>1</sup> Pin	Connects To	Description
FLAG0	LED3	FLAG2-0 connect to the LEDs. These can be used, for example, to light a LED when a routine completes.
FLAG1	LED2	
FLAG2	LED1	
FLAG3	AD1881A RESET	FLAG3 connects directly to the reset pin of the AD1881A audio codec. To reset the AD1881A, drive this signal low.

<sup>1</sup> FLAG3-0 are available on connector P2.

## Interrupt Pins

The ADSP-21160 processor holds three interrupt request ( $\sim$ IRQ) pins that let you interact with the running program. The  $\sim$ IRQ pins can be used only as inputs. To use the pins, enable the specific IRQ, as well as enable the global interrupts. You also need to write a special interrupt service routine to handle the interrupts when they occur.

## Example Programs

The signal locations can be found in “[ADSP-21160 EZ-KIT Lite Schematic](#)” on page B-1. The interrupt pins are summarized in [Table 1-3](#). For more information on configuring the  $\sim$ IRQ pins, see the *ADSP-21160 SHARC Processor Hardware Reference*.

Table 1-3. Interrupt Pin Summary

Interrupt <sup>1</sup>	Connects To	Description
IRQ0	SW3	IRQ2-0 connect to the push buttons and supply feedback for program execution. For instance, you can write your code to trigger a flag when a routine is complete.
IRQ1	SW4	
IRQ2	SW5	

1 IRQ2-0 are available on connector P2.

## Example Programs

Example programs are provided with the ADSP-21160 EZ-KIT Lite to demonstrate various capabilities of the evaluation board. These programs are installed with the EZ-KIT Lite software and can be found in the ...\<211xx\Examples\ADSP-21160 EZ-KIT Lite subdirectory of the VisualDSP++ installation directory. Please refer to the readme file provided with each example for more information.

## Flash Programmer Utility

The ADSP-21160 EZ-KIT Lite evaluation system includes a Flash Programmer utility. The utility allows you to program the flash memory on the EZ-KIT Lite. The Flash Programmer is installed with VisualDSP++. Once the utility is installed, it is accessible from the **Tools** pull-down menu.

For more information on the Flash Programmer utility, go to online Help.



# 2 ADSP-21160 EZ-KIT LITE HARDWARE

This chapter describes the hardware design of the ADSP-21160 EZ-KIT Lite board. The following topics are covered.

- [“System Architecture” on page 2-2](#)  
Describes the configuration of the ADSP-21160 EZ-KIT Lite board and explains how the board components interface with the processor.
- [“Jumper and Switches” on page 2-6](#)  
Shows the location and describes the function of the on-board jumper and DIP switch.
- [“LEDs and Push Buttons” on page 2-8](#)  
Shows the location and describes the function of the LEDs and push buttons.
- [“Connectors” on page 2-11](#)  
Shows the location and gives the part number for the on-board connectors. Also, the manufacturer and part number information is given for the mating parts.
- [“Specifications” on page 2-16](#)  
Provides the board’s measurements and power supply specifications.

## System Architecture

This section describes the processor's configuration on the EZ-KIT Lite board.

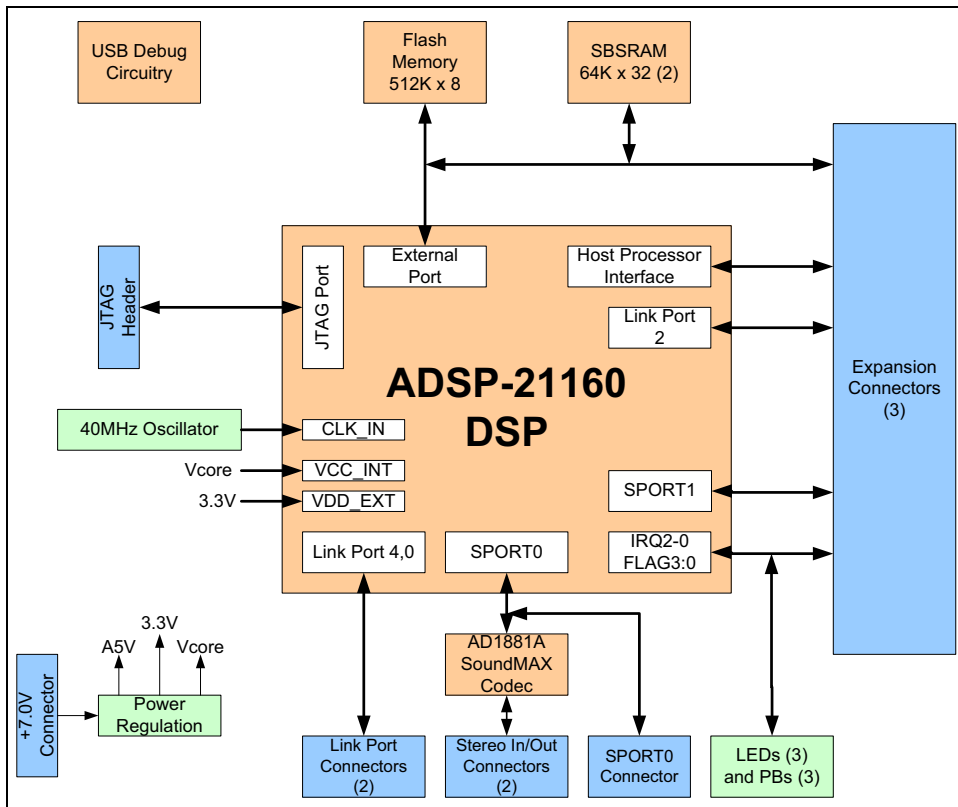

Figure 2-1. System Architecture Block Diagram

The ADSP-21160M processor's core voltage is 2.5V. The voltage of the processors' peripheral interface is 3.3V.

The core frequency of the processor is configured by multiplying the external oscillator by 2x. The EZ-KIT Lite board ships with a 40 MHz external oscillator.

The EZ-KIT Lite board can be configured to boot in all possible ADSP-21160 processor boot modes. The default boot mode is from the external 8-bit flash memory. For information about configuring the boot, see [“Boot Mode Select Switch \(SW1\)” on page 2-7](#).

### External Port

The external port (EP) of the processor connects to a 512 Kb (64K x 32-bits x 2-chips) SBSRAM. The SBSRAM connects to the memory select pin ( $\sim MS1$ ), providing a 64-bit memory interface.

The EP also connects to a 512 Kb (512K x 8-bits) flash memory. The flash memory connects to both the  $\sim BMS$  and  $\sim MS0$  memory select pins. The connection allows the processor to boot from the flash memory using  $\sim BMS$  and program it using  $\sim MS0$ .

All of the address, data, and control signals are available externally via the expansion connectors (P1–3). The pinout of these connectors can be found in [“ADSP-21160 EZ-KIT Lite Schematic” on page B-1](#).

## SPORT0 Audio Interface

SPORT0 connects to the AD1881A SoundMAX codec (U13). Two 3.5 mm stereo jacks (J4 and J5) allow audio to be input and output. You can supply an audio input to the codec microphone input channel (MIC1) or to the stereo input channel (LINE\_IN). The jumper settings of JP1 determine the codec channel driven by the input jack (J4). For information about configuring JP1, see [“Audio Input Selection Jumper \(JP1\)”](#) on page 2-6.

SPORT0 is also routed to an off-board connector (P11). When using the off-board connector, the codec must be held in reset not to drive any of the SPORT0 signals. The codec can be held in reset by driving FLAG3 low (0). The processor must drive FLAG3 high (1) to start the codec.

 The TCLK0 and RCLK0 pins are shorted together using R19 and R20.

## Expansion Interface

The expansion interface consists of three unpopulated connectors. [Table 2-1](#) shows the interfaces each connector provides. For the exact pinout of these connectors, refer to [“ADSP-21160 EZ-KIT Lite Schematic”](#) on page B-1. Analog Devices does not populate these connectors or provide any additional support for the interface. The mechanical dimensions of the connectors can be found in [“Board Current Measurements”](#) on page 2-16.

Table 2-1. Expansion Interface Connectors

Connector	Interfaces
P1	5V, GND, ADDRESS31-0, DATA47-0
P2	3.3V, GND, FLAG3-0, SPORT1, ~IRQ2-0, TIMEXP
P3	GND, RESET, LINKPORT2, memory control signals, D63-8

Limits to the current and to the interface speed must be taken into consideration when using the expansion interface. The maximum current limit is dependent on the capabilities of the regulator. Additional circuitry can also add extra loading to signals, decreasing their maximum effective speed.



Analog Devices does not support and is not responsible for the effects of additional circuitry.

### JTAG Emulation Port

The JTAG emulation port allows an emulator to access the processor's internal and external memory, as well as the special function registers, through a 14-pin interface. When an emulator connects to the board at ZP4, the USB debugging interface is disabled.

For a detailed description of the interface's connectors, see *EE-68* published on the Analog Devices Web site (go to <http://www.analog.com> and search for EE-68). For more information, see “[JTAG Connector \(ZP4\)](#)” on [page 2-14](#). For more information about available emulators, contact Analog Devices as described in “[Product Information](#)”.

# Jumper and Switches

This section describes the jumper and DIP switch functions. [Figure 2-2](#) shows the jumper and switch locations.

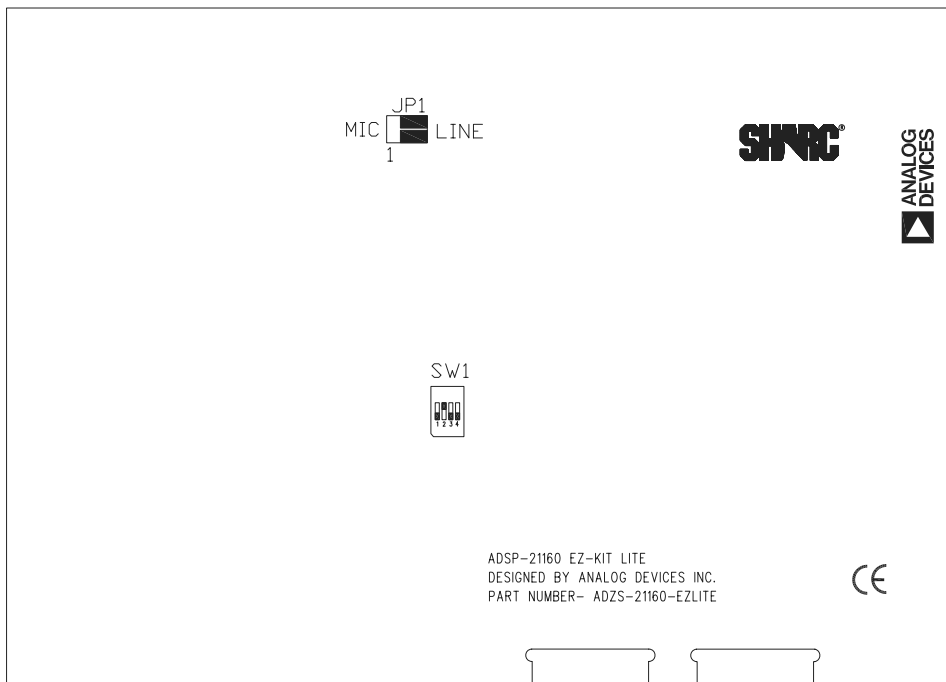

Figure 2-2. Jumper and Switch Locations

## Audio Input Selection Jumper (JP1)

The audio input jack (J4) can connect to the MIC1 or LINE\_IN input channel of the AD1881A codec (U13). When the JP1 jumper connects pins 1 and 3 and pins 2 and 4, J4 connects to the mono MIC1 channel. When the jumper connects pins 3 and 5 and pins 4 and 6, J4 connects to the stereo

LINE\_IN channel of the AD1881A codec. The jumper settings are illustrated in [Table 2-2](#). (The labels MIC and LINE appear on the board as a reference.)

Table 2-2. Audio Input Jumper Settings (JP1)

Stereo LINE_IN (Default)	Mono MIC1
<p>JP1</p>	<p>JP1</p>

## Boot Mode Select Switch (SW1)

The boot mode select switch (SW1) determines how the ADSP-21160 processor boots. [Table 2-3](#) shows the switch settings for the available boot modes.

Table 2-3. Boot Mode Select Switch (SW1) Settings

$\sim$ BMS Pin 1	LBOOT Pins 2	EBOOT Pins 3	Pin 4 not connected	Processor Boot Mode
OFF (output)	ON	OFF	OFF	Boot from 8-bit flash memory (default)
OFF (input)	ON	ON	X	Boot from host
OFF (input)	OFF	ON	X	Booting from link port
ON (input)	ON	ON	X	No boot (execute from external memory)
ON (input)	OFF	ON	X	Reserved
X (input)	OFF	OFF	X	Reserved

# LEDs and Push Buttons

This section describes the functionality of the LEDs and push buttons. [Figure 2-3](#) shows the locations of the LEDs and push buttons.

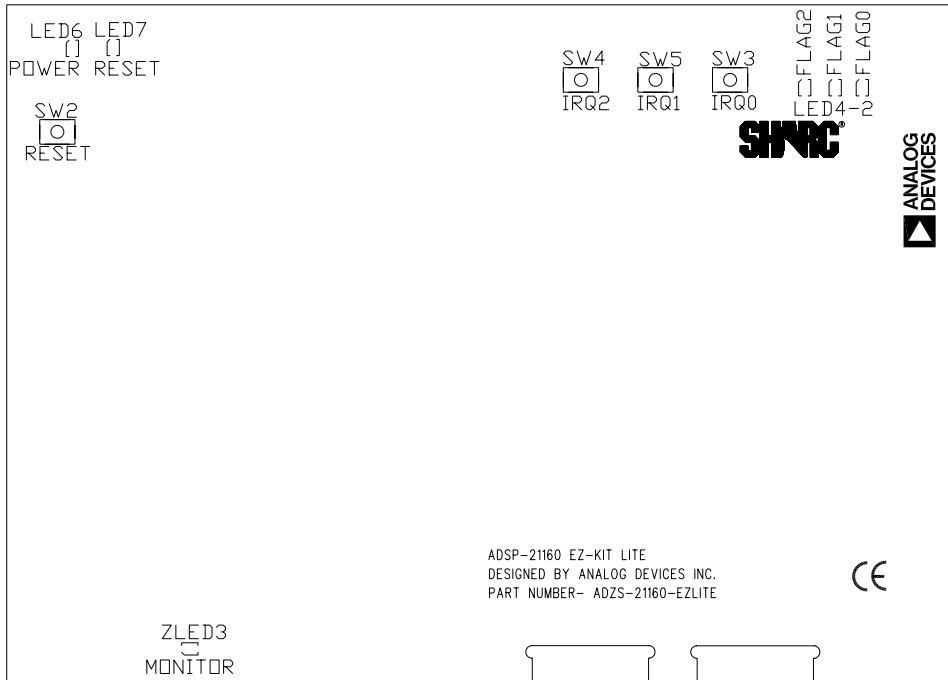

Figure 2-3. LED and Push Button Locations

## Reset LED (LED7)

When **LED7** is lit, the master reset of all the major ICs is active.

Reset LED does not necessarily indicate that the USB interface has been reset. The USB interface resets on power-up or when USB communication has not been initialized.



## Flag LEDs (LED2–4)

The flag LEDs connect to the processor’s flag pins (FLAG2–0). The LEDs are active high and are lit by an output of “1” from the processor. Refer to “LEDs and Push Buttons” on page 2-8 for more information on how to program the processor using flags. Table 2-4 shows the flag signals and the corresponding LEDs.

Table 2-4. Flag LEDs

Flag Pin	LED Reference Designator
FLAG0	LED2
FLAG1	LED3
FLAG2	LED4

## USB Monitor LED (ZLED3)

The USB monitor LED (ZLED3) indicates that USB communication has been initialized successfully, and you can connect to the processor using a VisualDSP++ EZ-KIT Lite session. If the LED does not light in approximately 15 second after the USB cable connects the board, try cycling power on the board and/or reinstalling the USB driver (see the *VisualDSP++ Installation Quick Reference Card*).

When VisualDSP++ is actively communicating with the EZ-KIT Lite target board, the LED can flicker, indicating communications handshake.

## Power LED (LED6)

When LED6 is lit (green), it indicates that power is being properly supplied to the board.

### Board Reset Push Button (SW2)

The RESET push button (SW2) resets all of the ICs on the board. The only exception is the USB interface chips. These chips are not being reset when the push button is pressed after the USB cable has been plugged in and communication correctly initialized with the PC. After USB communication has been initialized, the only way to reset the USB is by powering down the board.

### Interrupt Push Buttons (SW3–5)

Three push buttons connect to the three processor  $\sim$ IRQ pins. The pins are always input and, when asserted (0) and when interrupts are enabled, the processor goes to the corresponding interrupt vector. Refer to “[Interrupt Pins](#)” on page 1-9 for more information about the use of the IRQs when programming the processor. The push button reference designators and corresponding interrupt signals are summarized in [Table 2-5](#).

Table 2-5. Interrupt Push Buttons

Interrupt Signal	Push Button Reference Designator
IRQ0	SW3
IRQ1	SW4
IRQ2	SW5

## Connectors

This section describes the connector functionality and provides information about mating connectors. [Figure 2-4](#) shows the connector locations.

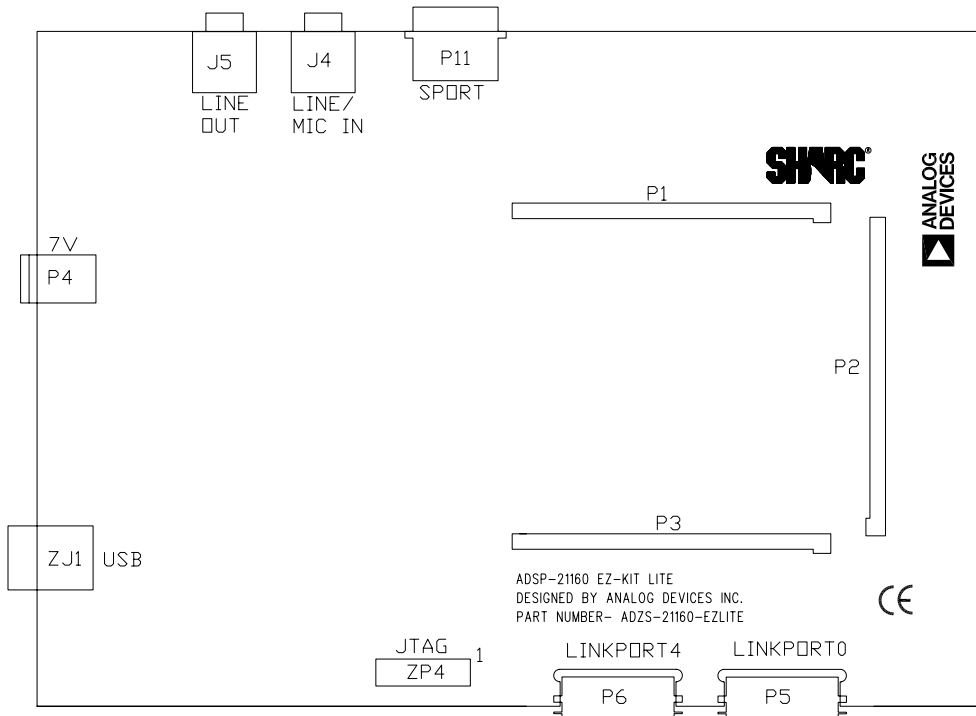

Figure 2-4. Connector Locations

## Connectors

### Expansion Connectors (P1–3)

Three board-to-board connectors provide signals for most of the processor's peripheral interfaces. Analog Devices does not populate the expansion connectors or provide any additional support for the interface. See [“Expansion Interface” on page 2-4](#) for more information on the expansion interface. Contact Samtec for the availability and pricing of the connectors. For the exact pinout of the connectors, refer to [“ADSP-21160 EZ-KIT Lite Schematic” on page B-1](#).

Part Description	Manufacturer	Part Number
90-position 0.05" spacing (P1, P2, P3)	SAMTEC	SFM-145-01-S-D
<b>Mating Connectors</b>		
90-position 0.05" spacing (through hole)	SAMTEC	TFM-145-x1 series
90-position 0.05" spacing (surface mount)	SAMTEC	TFM-145-x2 series
90-position 0.05" spacing (low cost)	SAMTEC	TFC-145 series

### Power Connector (P4)

The power connector (P4) provides all of the power necessary to operate the EZ-KIT Lite board.

Part Description	Manufacturer	Part Number
2.5 mm power jack (P4)	SWITCHCRAFT	RAPC712X
	DIGI-KEY	RAPC712X-ND
<b>Mating Power Supply (shipped with EZ-KIT Lite)</b>		
7.0V power supply	GLOBTEK	TR9CC2000LCP-Y

## Link Port Connectors (P5 and P6)

Each link port links to a 26-pin connector. Refer to *EE-106* found on the Analog Devices Web site at <http://www.analog.com> for more information about the link port connectors.

Part Description	Manufacturer	Part Number
26-position connector (P5, P6)	HONDA	RMCA-EA26LMY-0M03-A+
<b>Mating Connectors</b>		
Cable assembly (30 cm)	ANALOG DEVICES	ADDS-LPCAB-30
Cable connector	HONDA	RMCA-E26F1S-A
Shroud	HONDA	RMCA-E26L1A
Coaxial cable	GORE	DXN2132

## USB Connector (ZJ1)

The USB connector (ZJ1) is a standard Type B USB receptacle. The USB connector is used to debug the processor. The connectors does not link to the processor's USB interface.

Part Description	Manufacturer	Part Number
Type B USB receptacle	MILL-MAX	897-30-004-90-000000
	DIGI-KEY	ED90064-ND
<b>Mating Connector (provided with the EZ-KIT Lite)</b>		
USB cable	ASSMANN	AK672-5
	DIGI-KEY	AK672-5ND

## Connectors

### JTAG Connector (ZP4)

The JTAG header (ZP4) is the connecting point for a JTAG in-circuit emulator pod. When an emulator is connected to the JTAG header, the USB debug interface is disabled.

Pin 3 is missing to provide keying. Pin 3 in the mating connector should have a plug.



When using an emulator with the EZ-KIT Lite board, follow the connection instructions provided with the emulator.

Part Description	Manufacturer	Part Number
14-pin IDC header (P8)	FCI	68737-414HLF

### Audio Connectors (J4 and J5)

There are two 3.5 mm stereo audio jacks: one input and one output.

Part Description	Manufacturer	Part Number
3.5 mm stereo jack (J4 and J5)	A/D ELECTRONICS	ST-323-5
<b>Mating Connector</b>		
3.5 mm stereo plug to 3.5 mm stereo cable	RADIO SHACK	42-2387A

## SPORT0 Connector (P11)

SPORT0 links to a 20-pin connector. The connector pinout can be found in [“ADSP-21160 EZ-KIT Lite Schematic”](#) on page B-1.

Part Description	Manufacturer	Part Number
20-position AMPMODU system 50 receptacle (P11)	TYCO	5-104069-1
<b>Mating Connectors</b>		
20-position AMPMODU system 20 connector	AMP	2-487937-0
20-position AMPMODU system 20 connector (w/o lock)	AMP	2-487938-0
Flexible film contacts (20 per connector)	AMP	487547-1
<b>Mating Assembly</b>		
Straight-through assembly with locking connector on each end	GOPHER ELECTRONICS	DRFFC10X7RHU-RHU5

# Specifications

The following board specifications are covered in this section.

- [“Power Supply” on page 2-16](#)
- [“Board Current Measurements” on page 2-16](#)

## Power Supply

The power connector supplies DC power to the EZ-KIT Lite board. [Table 2-6](#) shows the power supply specifications.

Table 2-6. Power Supply Specifications

Terminal	Connection
Center pin	+7.0V@2 amps
Outer ring	GND

## Board Current Measurements

The ADSP-21160M EZ-KIT Lite board provides two zero-ohm resistors that can be removed to measure current draw. [Table 2-7](#) shows the resistor number and the voltage plane measurable at that location.

Table 2-7. Current Measurements

Resistor	Voltage Plane	Description
R7	VDD_EXT	Core voltage of the processor
R6	VDD_INT	IO voltage of the processor



# A ADSP-21160 EZ-KIT LITE BILL OF MATERIALS

The bill of materials corresponds to “[ADSP-21160 EZ-KIT Lite Schematic](#)” on page B-1. Please check the latest schematic on the Analog Devices Web site:

<http://www.analog.com/processors/sharc/technicalLibrary/manuals/index.html#Evaluation%20Kit%20Manuals>.

Ref.	Qty.	Description	Reference Designator	Manufacturer	Part Number
1	1	74LVC14A SOIC14	U7	TI	74LVC14AD
2	1	IDT74FCT32 44APY SSOP20	U6	IDT	IDT74FCT3244APYG
3	1	24.576MHZ OSC005	Y1	EPSON	MA-505 24.5760M-C3:ROHS
4	1	74LVC00AD SOIC14	U5	PHILIPS	74LVC00AD
5	2	MT58L64L32 TQFP100_B	U8-9	CYPRESS	CY7C199D-12VXI
6	1	LT1765 SOIC8	VR3	LINEAR TECH	LT1765ES8#PBF
7	1	40MHZ OSC003	U2	DIGI-KEY	SG-8002CA-PCC-ND (40.000M)
8	1	FDC658P SOT23-6	U11	FAIRCHILD	FDC658P
9	1	AD1881AJST Z LQFP48	U13	ANALOG DEVICES	AD1881AJSTZ

Ref.	Qty.	Description	Reference Designator	Manufacturer	Part Number
10	1	ADM708SARZ SOIC8	U4	ANALOG DEVICES	ADM708SARZ
11	1	ADP3339AKCZ-5 SOT-223	VR5	ANALOG DEVICES	ADP3339AKCZ-5-R7
12	1	AD8532ARZ SOIC8	U10	ANALOG DEVICES	AD8532ARZ
13	1	ADSP-21160 MKBZ-80 PBGA400	U1	ANALOG DEVICES	ADSP-21160MKBZ-80
14	1	ADP1864 SOT23-6	VR1	ANALOG DEVICES	ADP1864AUJZ-R7
15	5	RUBBER FOOT	M1-5	MOUSER	517-SJ-5018BK
16	1	PWR 2.5MM_JACK CON005	P4	SWITCHCRAFT	RAPC712X
17	2	LNKPRT 12X2 CON010	P5-6	HONDA(TSUSHI NK)	RMCA-EA26LMY-0M03-A+
18	1	.05 10X2 CON014	P11	TYCO	5-104069-1
19	4	MOMENTARY SWT013	SW2-5	PANASONIC	EVQ-PAD04M
20	1	DIP4 SWT018	SW1	ITT	TDA04HOSB1
21	1	IDC 7X2 IDC7X2	ZP4	FCI	68737-414HLF
22	1	2.5A RESETABLE FUS001	F1	RAYCHEM	SMD250F-2

## ADSP-21160 EZ-KIT Life Bill Of Materials

Ref.	Qty.	Description	Reference Designator	Manufacturer	Part Number
23	2	IDC 2PIN_JUMPE R_SHORT	SJ1-2	DIGI-KEY	S9001-ND
24	2	3.5MM STEREO_JAC K CON001	J4-5	A/D ELECTRON- ICS	ST-323-5
25	1	IDC 3X2 IDC3X2	JP1	SULLINS	GEC03DAAN
26	9	0 1/4W 5% 1206	R6-7,R18-20, R28,R68-70	KOA	0.0ECTRk7372BTTED
27	2	220UF 10V 20% E	CT2-3	AVX	TAJE227K010R
28	3	YELLOW LED001	LED2-4	PANASONIC	LN1461C
29	2	22PF 50V 5% 0805	C5-6	AVX	08055A220JAT
30	21	0.01UF 100V 10% 0805	C25,C44,C53-5 4,C62,C64-65, C70,C74-75, C77-78,C82-87, C89,C91,C100	AVX	08051C103KAT2A
31	1	0.22UF 25V 10% 0805	C3	AVX	08053C224FAT
32	25	0.1UF 50V 10% 0805	C24,C26,C34, C45,C51-52, C55-57,C59-60, C63,C66-69, C71-73,C88, C90,C92-93, C95,C98	AVX	08055C104KAT
33	2	10UF 16V 10% C	CT7-8	AVX	TAJC106K016R

Ref.	Qty.	Description	Reference Designator	Manufacturer	Part Number
34	10	10K 1/10W 5% 0805	R1,R5,R57,R65- 67,R72,R74, R76,R84	VISHAY	CRCW080510K0JNEA
35	2	33 1/10W 5% 0805	R2-3	VISHAY	CRCW080533R0JNEA
36	1	10.5K 1/8W 1% 1206	R81	VISHAY	CRCW120610K5FKEA
37	1	2.21K 1/8W 1% 1206	R29	KOA	RK73H2BTDD2211F
38	3	10UF 16V 10% B	CT1,CT9-10	AVX	TAJB106K016R
39	1	2A SS26-TR DO-214AA	D7	VISHAY	SS26-E3/1
40	8	22K 1/10W 5% 0805	R16,R24,R27, R85-87,R90-91	VISHAY	CRCW080522K0JNEA
41	3	100 1/10W 5% 0805	R64,R71,R75	VISHAY	CRCW0805100RJNEA
42	4	2A S2A DO-214AA	D1-2,D4-5	MICRO COMM	S2A-TP
43	7	600 100MHZ 500MA 1206	FER1-4,FER6-8	STEWARD	HZ1206B601R-10
44	1	0.047UF 16V 10% 1206	C11	AVX	12065C473JATME
45	2	270PF 50V 10% 1206	C12,C19	AVX	12061A271JAT2A
46	8	1UF 16V 10% 0805	C1-2,C4,C7, C27,C37,C41, C43	PANASONIC	ECJ2FB1E105K
47	4	470PF 100V 10% 1206	C13-16	AVX	12061A471JAT2A
48	1	10 1/10W 5% 0805	R83	VISHAY	CRCW080510R0FKEA

## ADSP-21160 EZ-KIT Life Bill Of Materials

Ref.	Qty.	Description	Reference Designator	Manufacturer	Part Number
49	5	10UF 25V +80-20% 1210	C22,C46-49	PANASONIC	ECJ4YF1E106Z
50	1	10UH 20% IND001	L2	TDK	445-2014-1-ND
51	1	10K 31MW 5% RNET8	RN1	CTS	746X101103JP
52	8	0 1/10W 5% 0805	R4,R8-12,R17, R89	VISHAY	CRCW08050000Z0EA
53	1	11.3K 1/10W 1% 0805	R82	DIGI-KEY	311-11.3KCRTR-ND
54	1	190 100MHZ 5A FER002	FER9	MURATA	DLW5BSN191SQ2
55	4	40A VC0805 0805	D3,D8-10	AVX	VC080505A150DPLC
56	1	68PF 50V 5% 0603	C20	AVX	06035A680JAT2A
57	1	470PF 50V 5% 0603	C18	AVX	06033A471JAT2A
58	1	0 1/10W 5% 0603	R36	PHYCOMP	232270296001L
59	1	24.9K 1/10W 1% 0603	R35	DIGI-KEY	311-24.9KHTR-ND
60	1	47UF 6.3V 10% B	CT12	NIC COMPO- NENTS	NTC-T476K6.3TRBF
61	1	0.05 1/2W 1% 1206	R37	SUSUMA	RL16326-R050-F-N
62	1	10UF 16V 10% 1210	C28	AVX	1210YD106KAT2A
63	1	680 1/8W 5% 1206	R33	VISHAY	CRCW1206680RFNEA

Ref.	Qty.	Description	Reference Designator	Manufacturer	Part Number
64	1	GREEN LED001	LED6	PANASONIC	LN1361CTR
65	1	REDLED001	LED7	PANASONIC	LN1261CTR
66	2	1000PF 50V 5% 1206	C40,C42	AVX	12065A102JAT2A
67	1	2200PF 50V 5% 1206	C23	AVX	12065A222JAT050
68	1	100K 1/8W 5% 1206	R88	VISHAY	CRCW1206100KFKEA
69	4	270 1/8W 5% 1206	R30-32,R34	VISHAY	CRCW1206270RJNEA
70	4	1UF 20V 20% A	CT4-6,CT11	AVX	TAJA105K020R
71	2	0.1UF 50V 10% 1206	C9-10	AVX	12065C104KAT1A
72	4	10K 1/8W 5% 1206	R13-15,R21	VISHAY	CRCW120610K0JNEA
73	4	4.7K 1/8W 5% 1206	R22-23,R25-26	VISHAY	CRCW12064K70JNEA
74	1	255.0K 1/10W 1% 0603	R39	VISHAY	CRCW06032553FK
75	1	80.6K 1/10W 1% 0603	R38	DIGI-KEY	311-80.6KHRCT-ND
76	1	6.8UH 25% IND009	L1	DIGI-KEY	308-1328-1-ND
77	1	4A SSB43L DO-214AA	D6	VISHAY	SSB43L

A

B

C

D

# ADSP-21160 EZ-KIT Lite

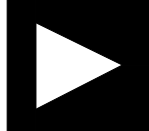
		<b>ANALOG DEVICES</b>	20 Cotton Road Nashua, NH 03063 PH: 1-800-ANALOGD
<b>Title</b>		ADSP-21160 EZ-KIT LITE TITLE	
<b>Size</b> C	<b>Board No.</b>	A0164-2001	<b>Rev</b> 2.0
<b>Date</b>	8-24-2006_9:22	<b>Sheet</b>	1 of 8

A

B

C

D

1

1

2

2

3

3

4

4

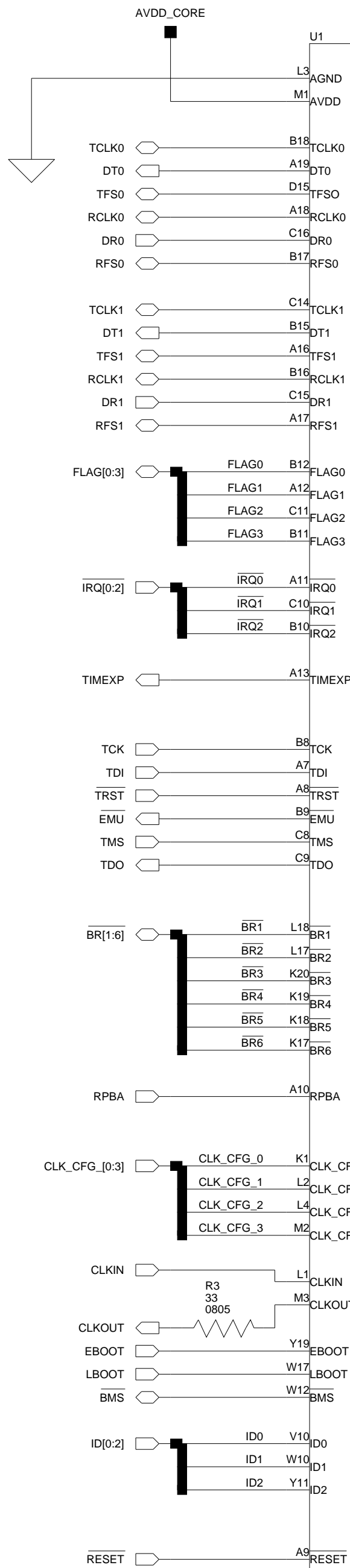

ADSP-21160MKBZ-80  
PBGA400

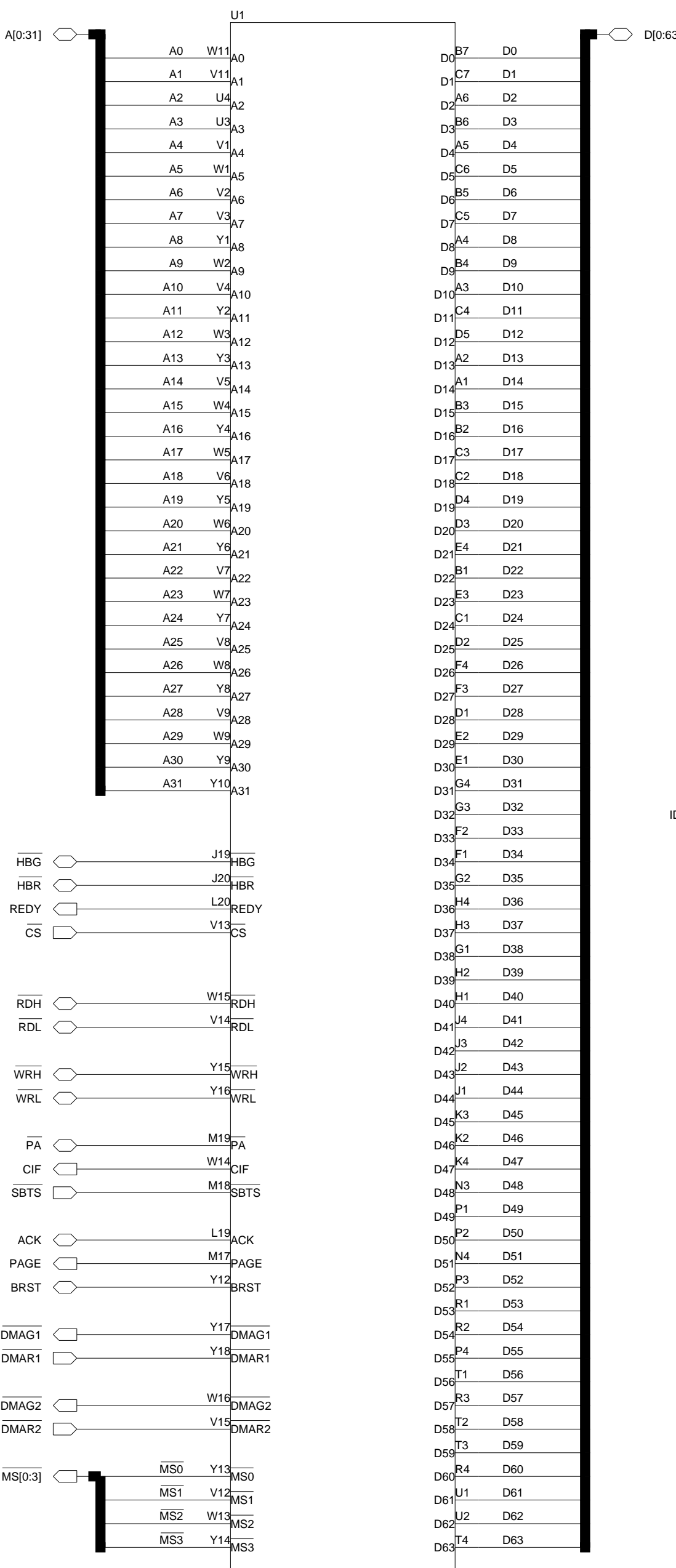

ADSP-21160MKBZ-80  
PBGA400

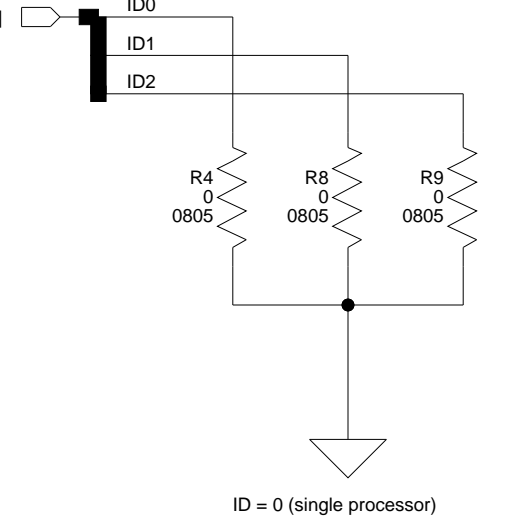
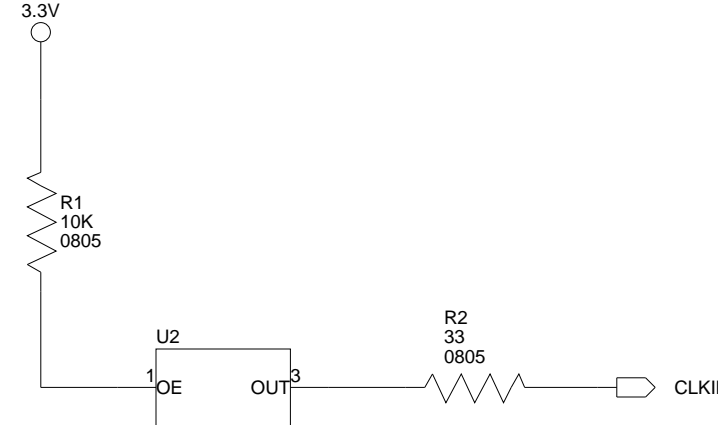
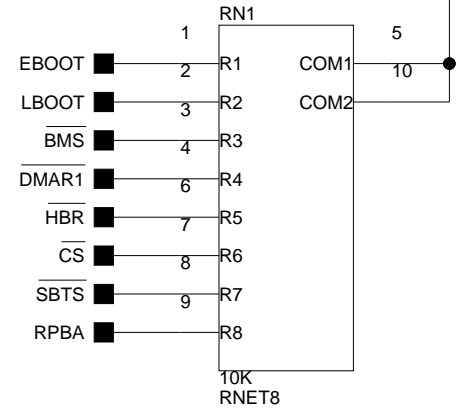
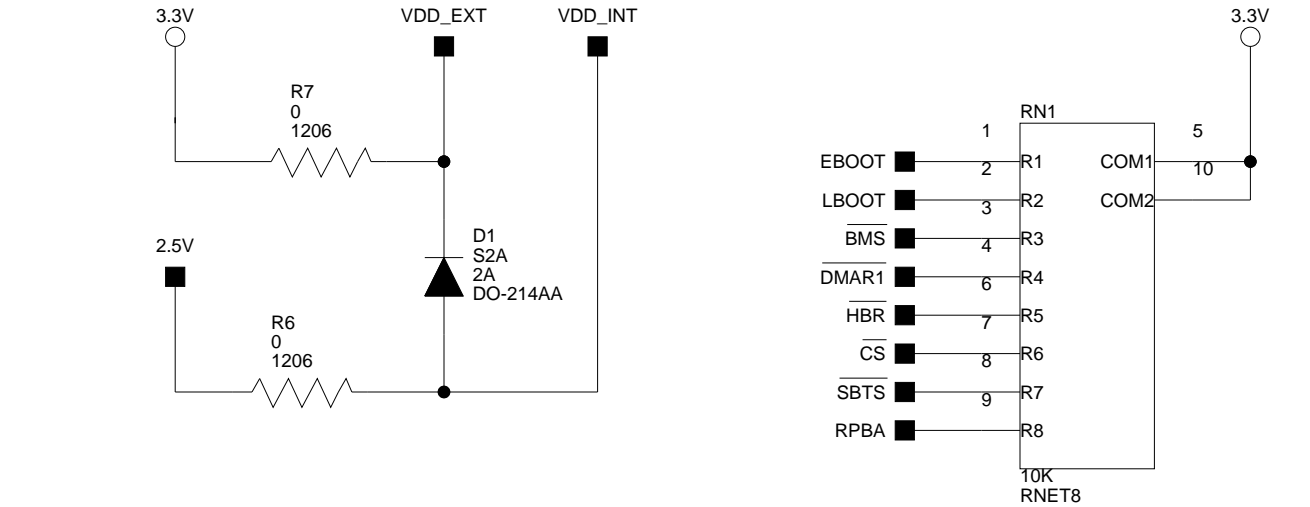

ID = 0 (single processor)

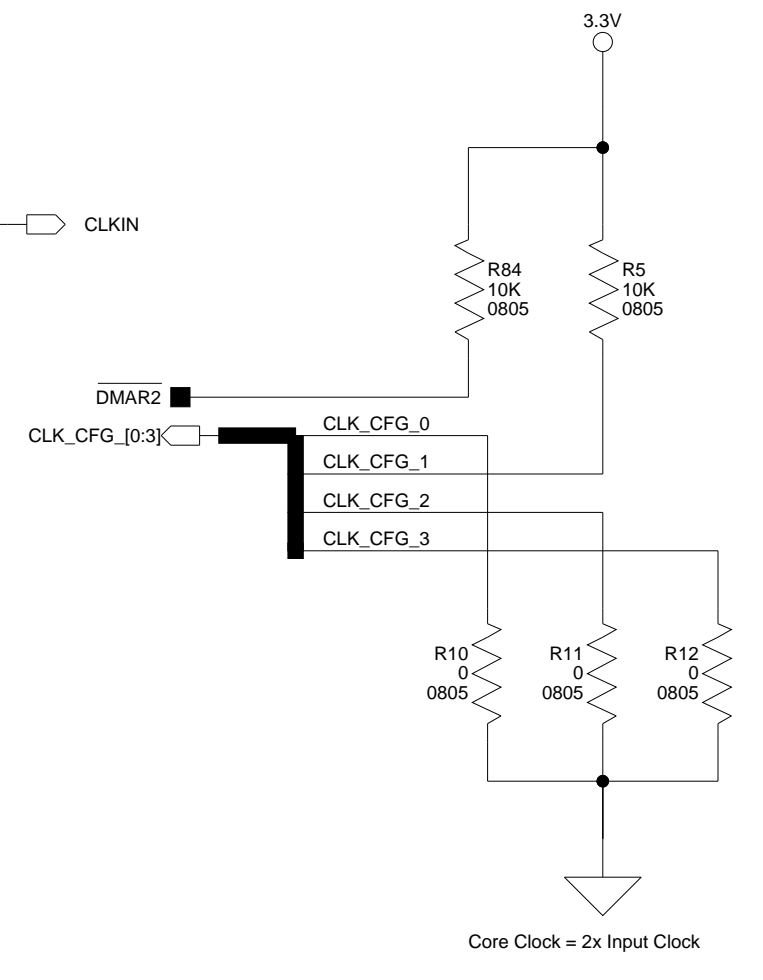

Core Clock = 2x Input Clock

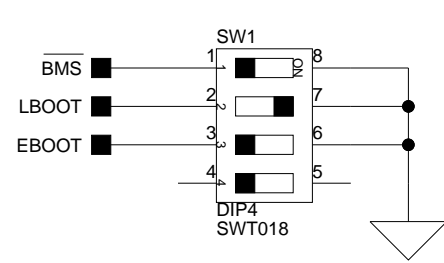

SW1 SETTINGS: BOOT MODE SELECTION

EBOOT	LBOOT	-BMS	BOOT MODE
OFF	ON	OFF (OUTPUT)	FLASH (BMS OUTPUT TO FLASH CE)
ON	ON	OFF (INPUT)	HOST PROCESSOR
ON	OFF	OFF (INPUT)	LINK PORT
ON	ON	ON (INPUT)	NO BOOT
ON	OFF	ON (INPUT)	RESERVED
OFF	OFF	X (INPUT)	RESERVED

\* = DEFAULT

**ANALOG DEVICES**  
20 Cotton Road  
Nashua, NH 03063  
PH: 1-800-ANALOGD

Title <b>ADSP-21160 EZ-KIT LITE DSP</b>			
Size C	Board No.	A0164-2001	
Date	8-16-2006_15:00	Sheet	2 of 8
		Rev	2.0



SBSRAM  
4Mb (64K x 32-BIT x 2-CHIPS)

FLASH  
512K X 8-BIT

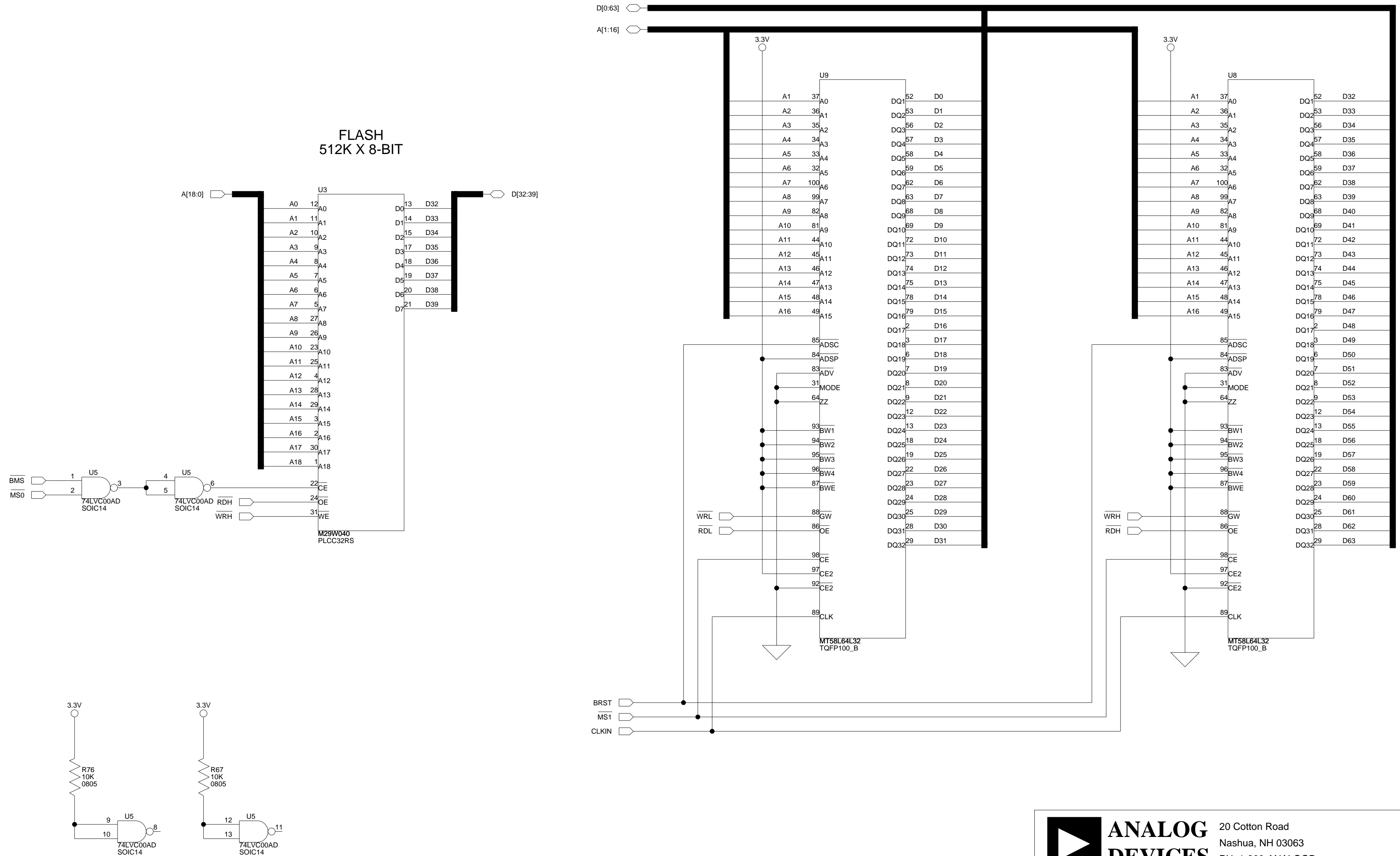

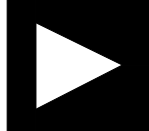
 <b>ANALOG DEVICES</b>		20 Cotton Road Nashua, NH 03063 PH: 1-800-ANALOGD	
		<b>Title</b> ADSP-21160 EZ-KIT LITE <b>MEMORY</b>	
<b>Size C</b>	<b>Board No.</b> A0164-2001	<b>Rev</b> 2.0	
<b>Date</b> 8-24-2006_9:42	<b>Sheet</b> 3 of 8		

SJ2  
SHORTING  
JUMPER  
DEFAULT=4&6

SJ1  
SHORTING  
JUMPER  
DEFAULT=3&5

JP1 SETTINGS

SJ1	SJ2	INPUT SOURCE
1 & 3	2 & 4	MIC IN
3 & 5	4 & 6	LINE IN

\* Denotes Default Setting

POPULATE TO COMPLY WITH PC99

**AUDIO CODEC  
AD1881A**

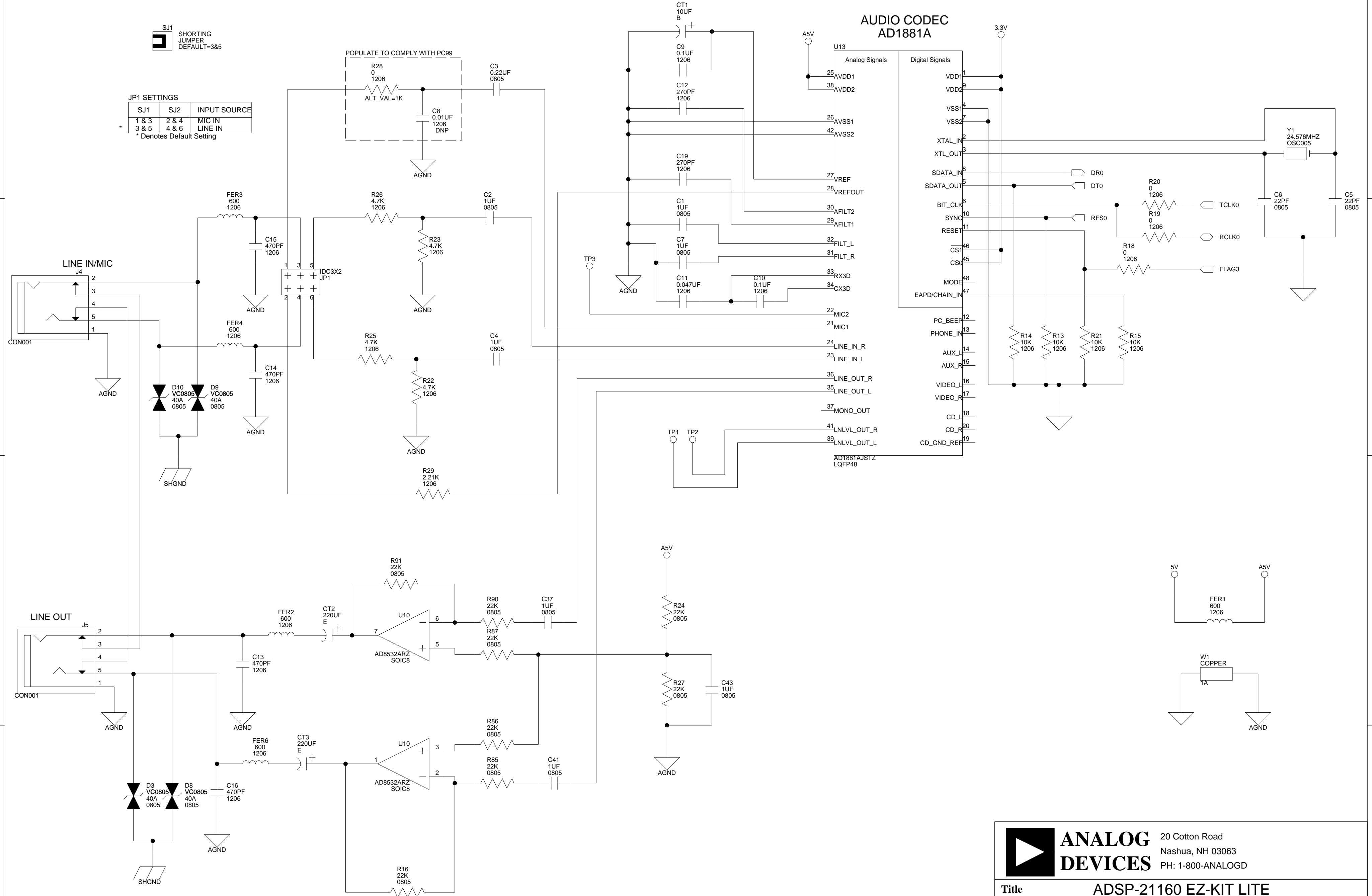

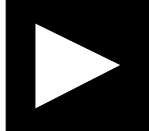
 <b>ANALOG DEVICES</b>		20 Cotton Road Nashua, NH 03063 PH: 1-800-ANALOGD	
		<b>Title</b> ADSP-21160 EZ-KIT LITE AUDIO CODEC	
<b>Size C</b>	<b>Board No.</b> A0164-2001	<b>Rev</b> 2.0	
<b>Date</b> 10-4-2006_17:45	<b>Sheet</b> 4 of 8		

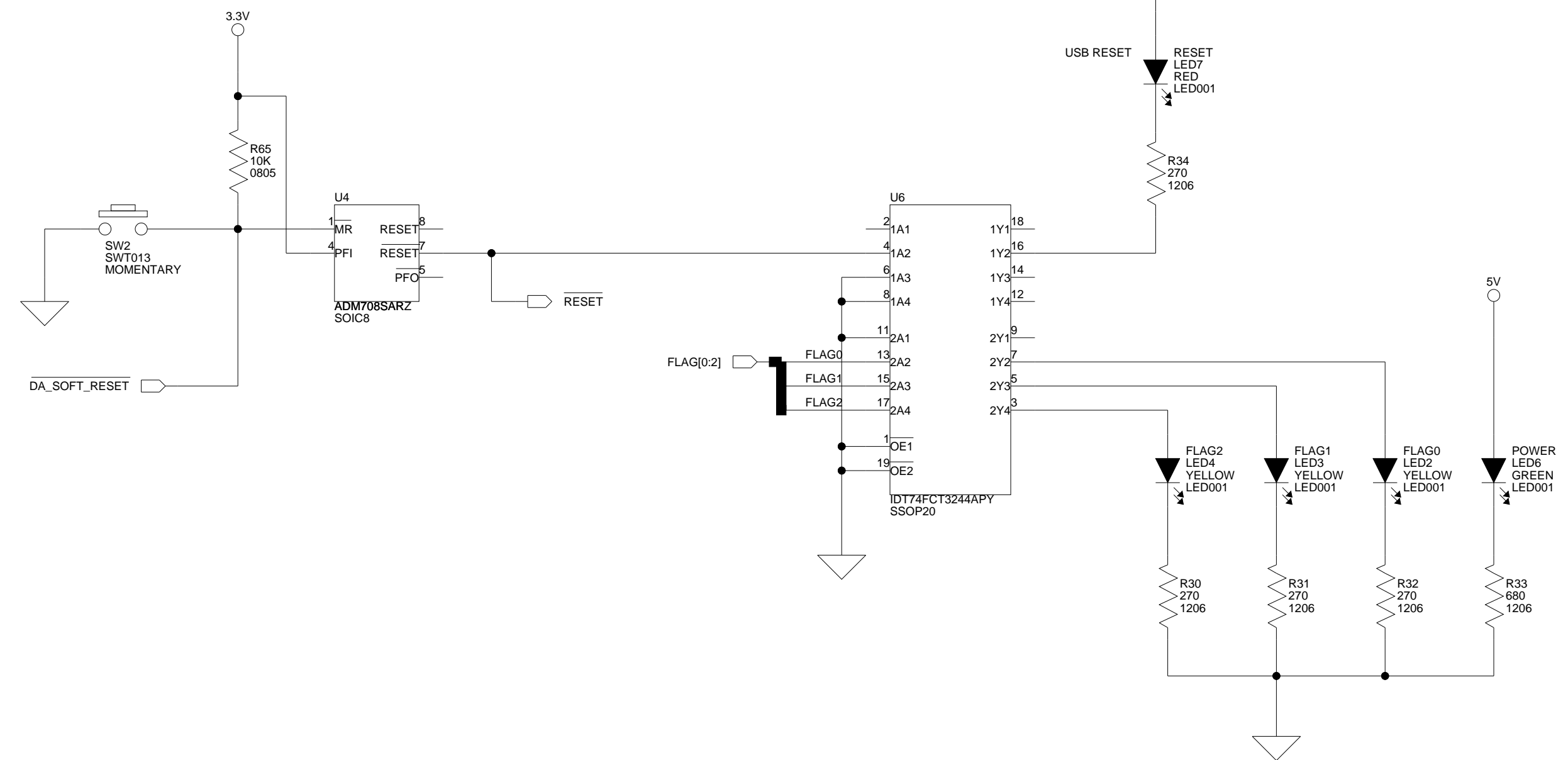
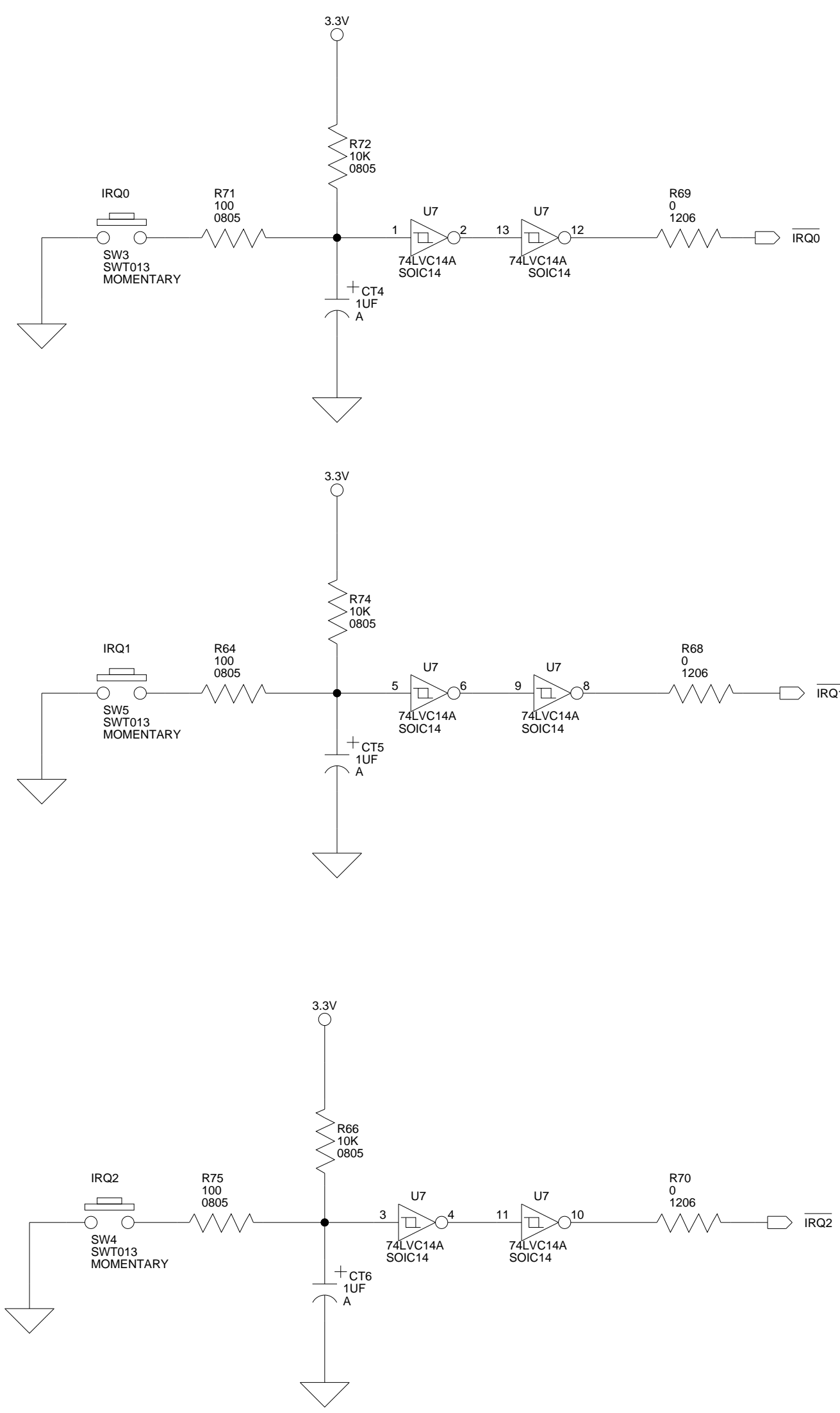

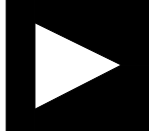
 <b>ANALOG DEVICES</b>		20 Cotton Road Nashua, NH 03063 PH: 1-800-ANALOGD	
		<b>Title</b> ADSP-21160 EZ-KIT LITE PB/LED	
<b>Size C</b>	<b>Board No.</b>	<b>Rev</b>	<b>2.0</b>
<b>Date</b> 8-16-2006_15:00	<b>Sheet</b> 5 <b>of</b> 8		

### LINK PORT CONNECTORS

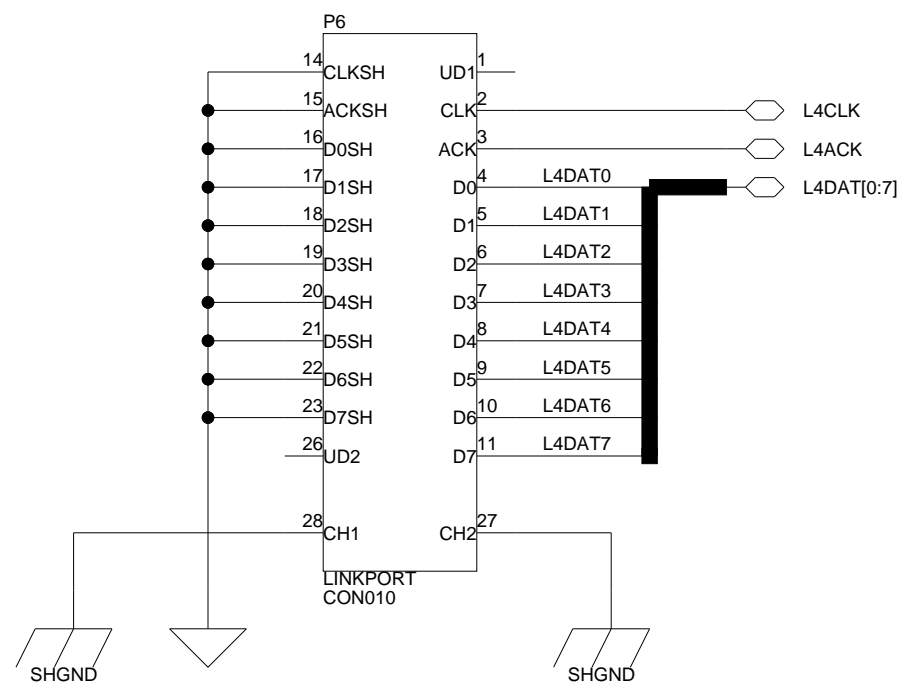
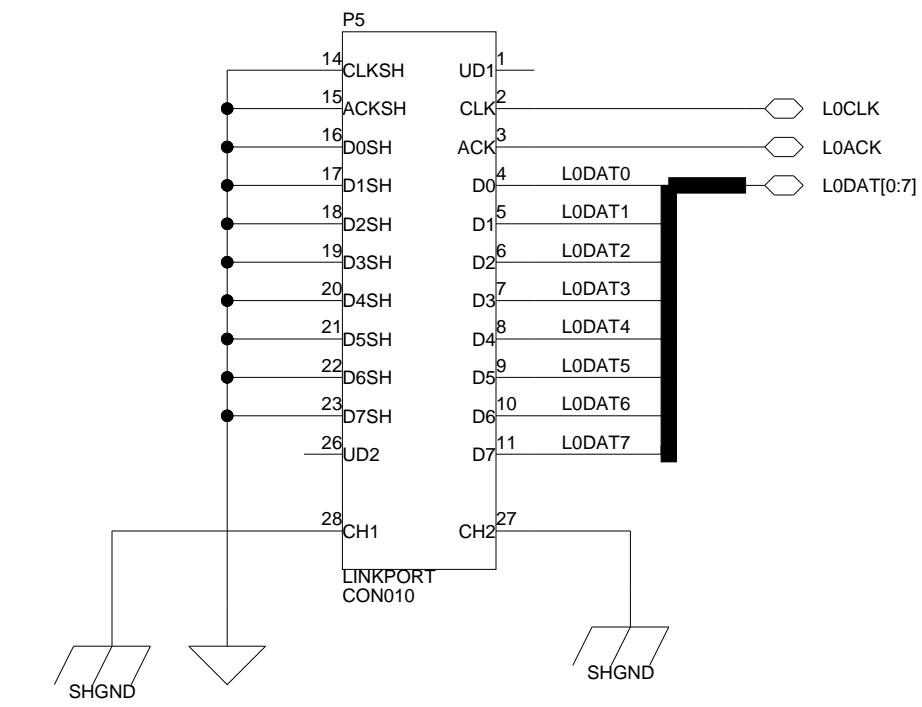

### SPORT0

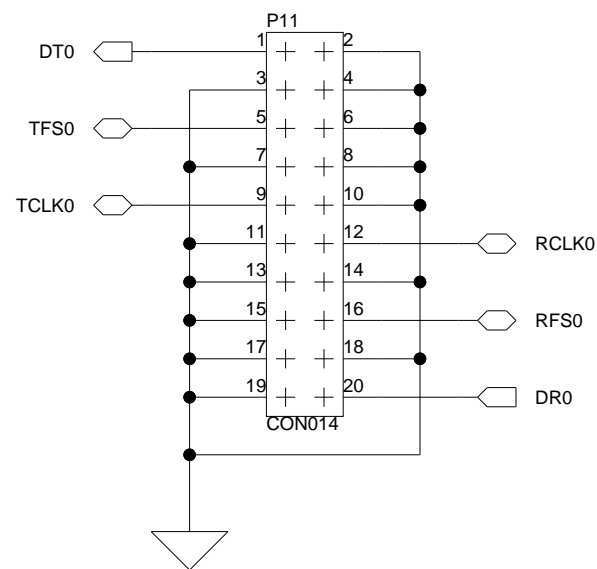

### DSP JTAG HEADER

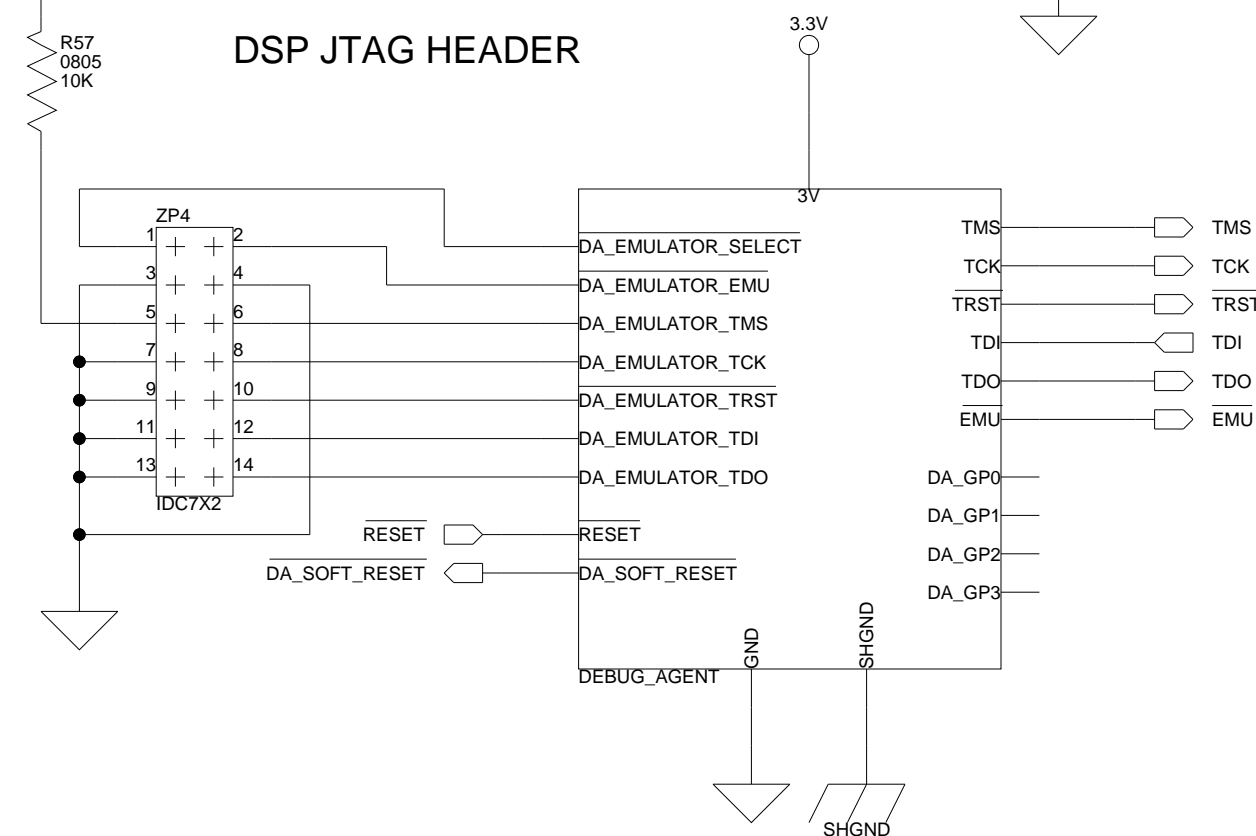

All USB interface circuitry is considered proprietary and has been omitted from this schematic.

When designing your JTAG interface please refer to the Engineer to Engineer Note EE-68 which can be found at <http://www.analog.com>

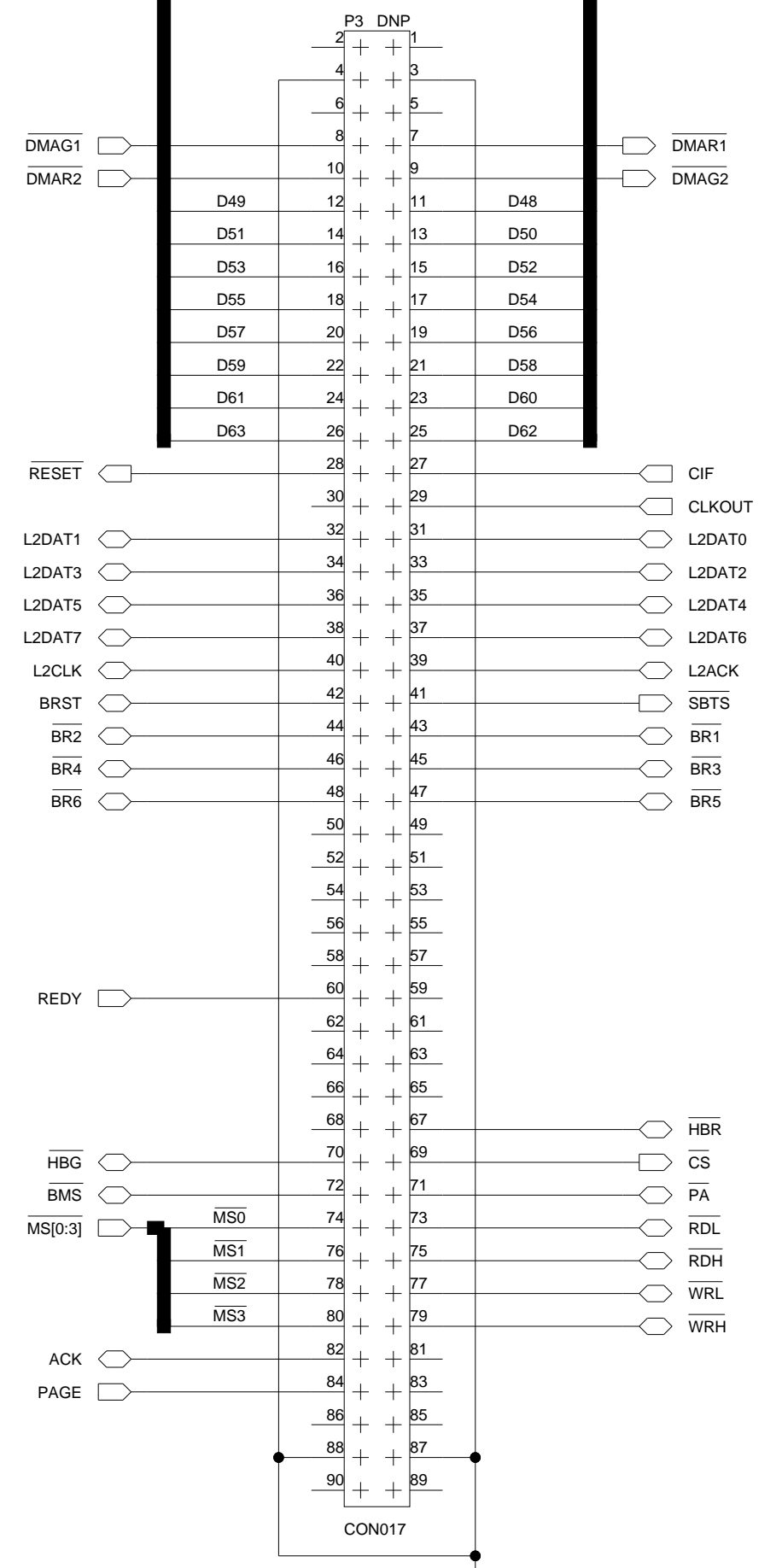
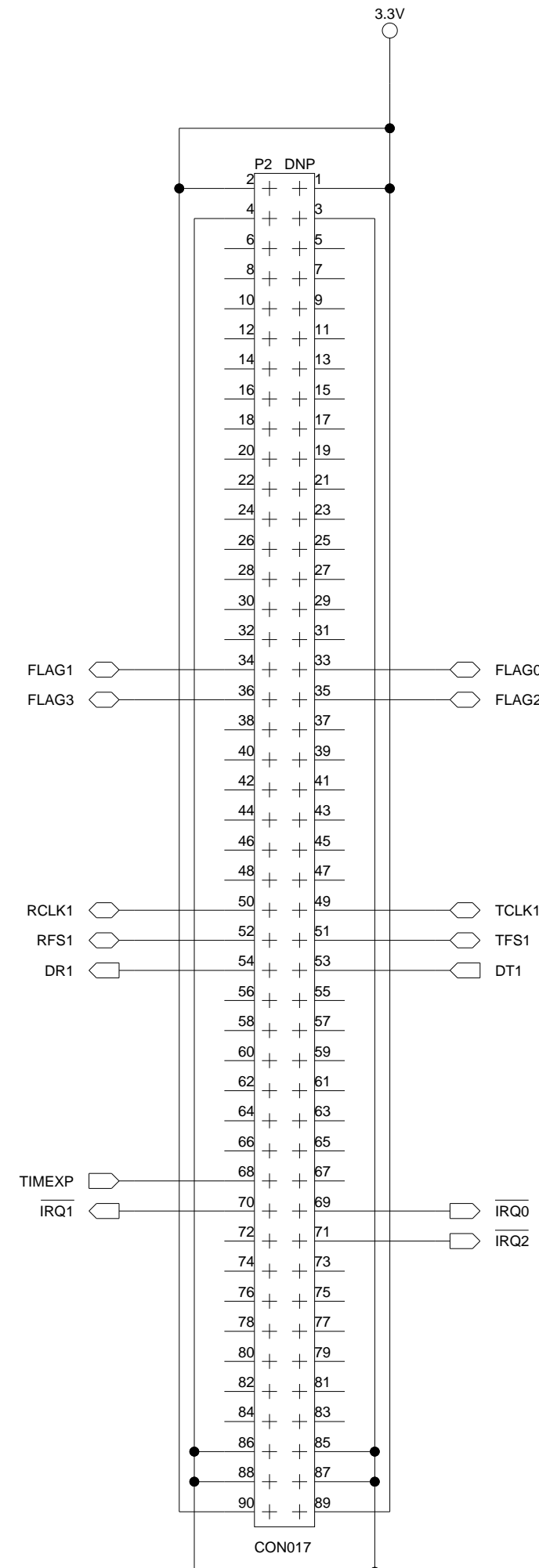
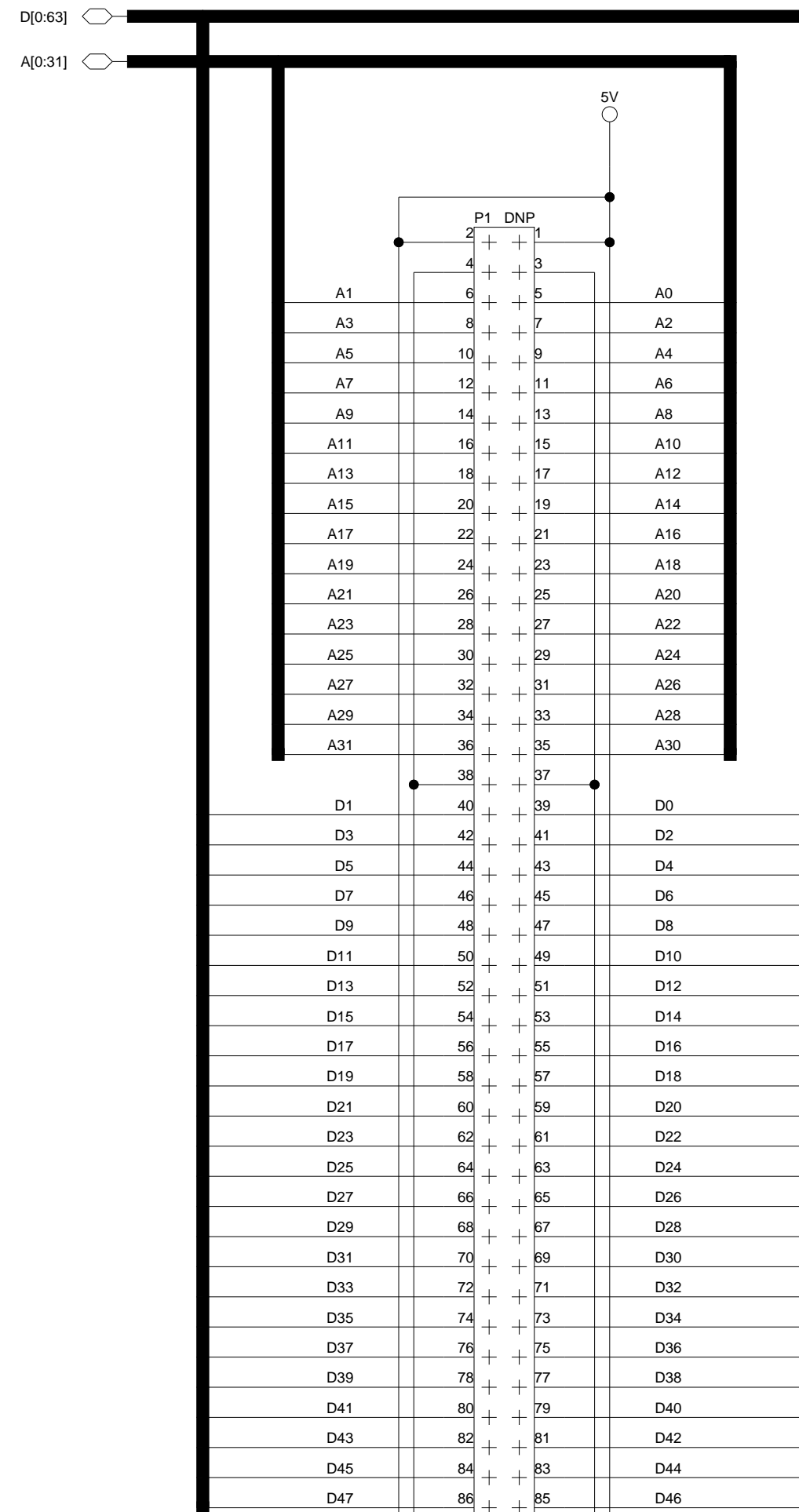

		20 Cotton Road Nashua, NH 03063 PH: 1-800-ANALOGD		
		<b>Title</b> ADSP-21160 EZ-KIT LITE CONNECTORS		
<b>Size C</b>	<b>Board No.</b>	A0164-2001	<b>Rev</b>	2.0
<b>Date</b>	8-16-2006_15:00	<b>Sheet</b>	6 of	8

A

B

C

D

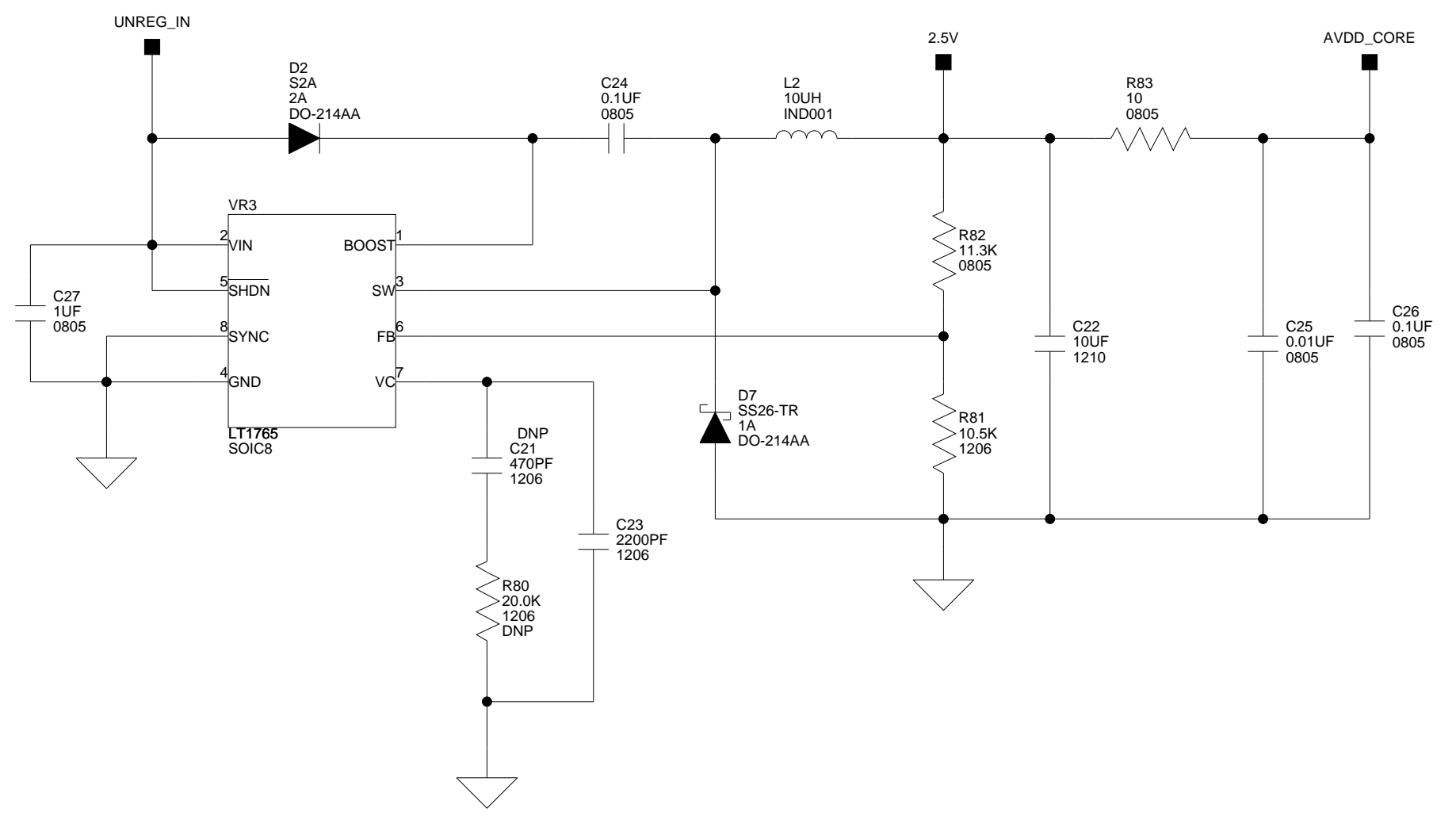
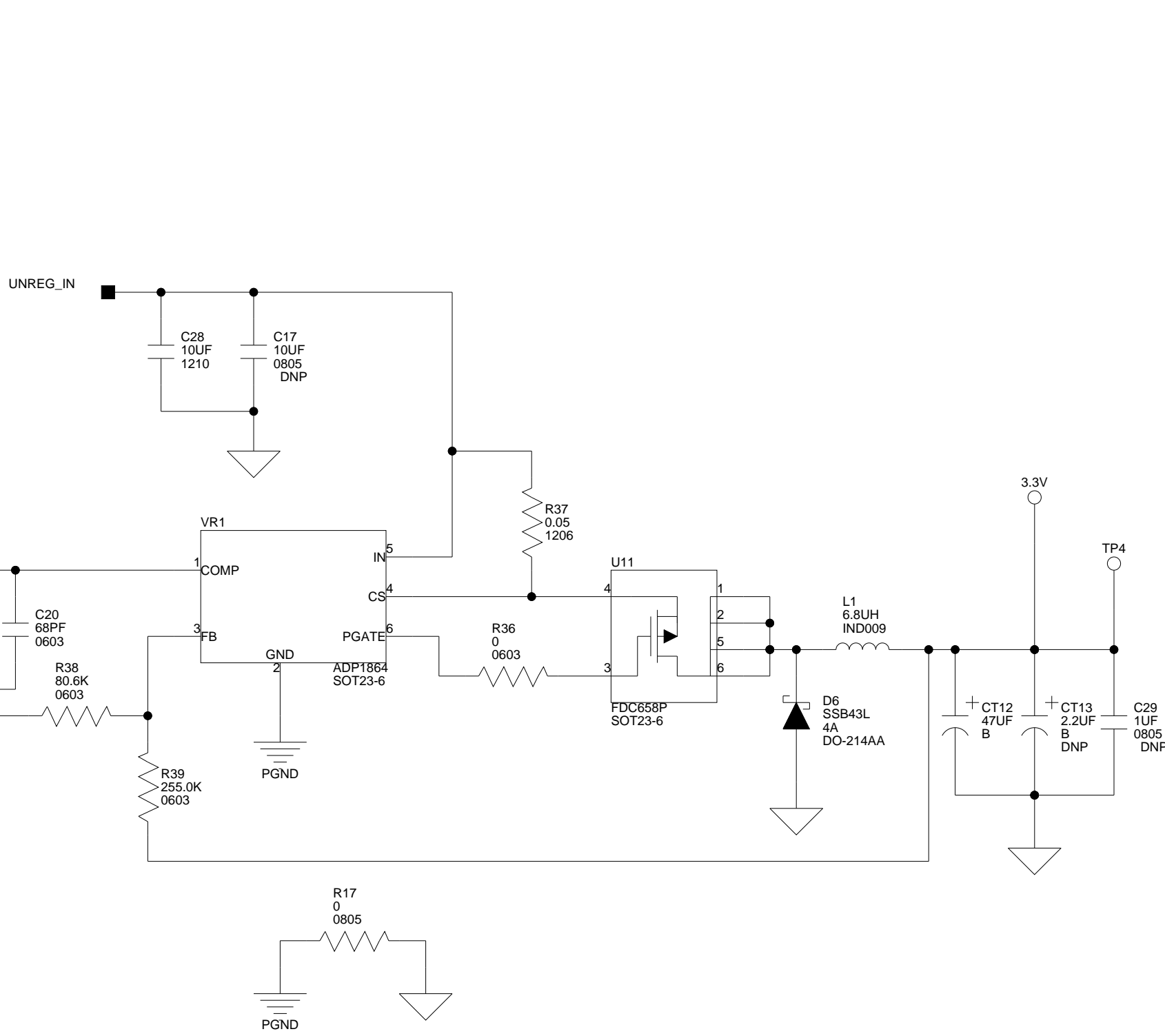
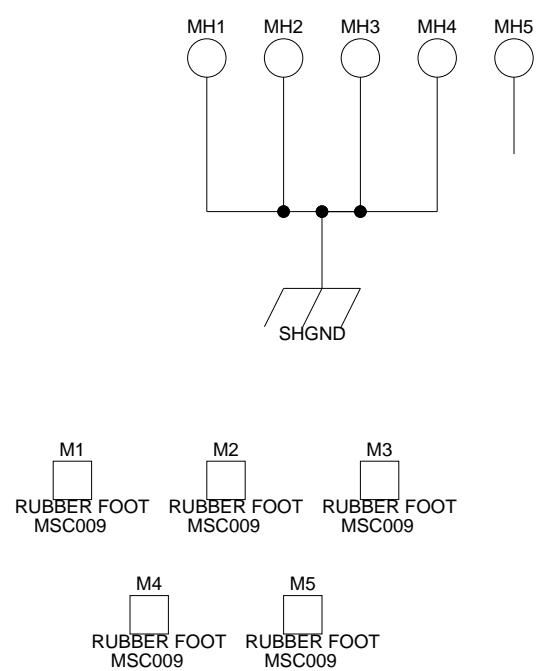
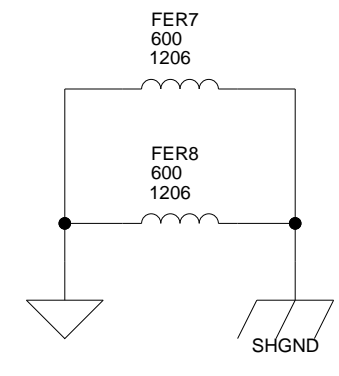
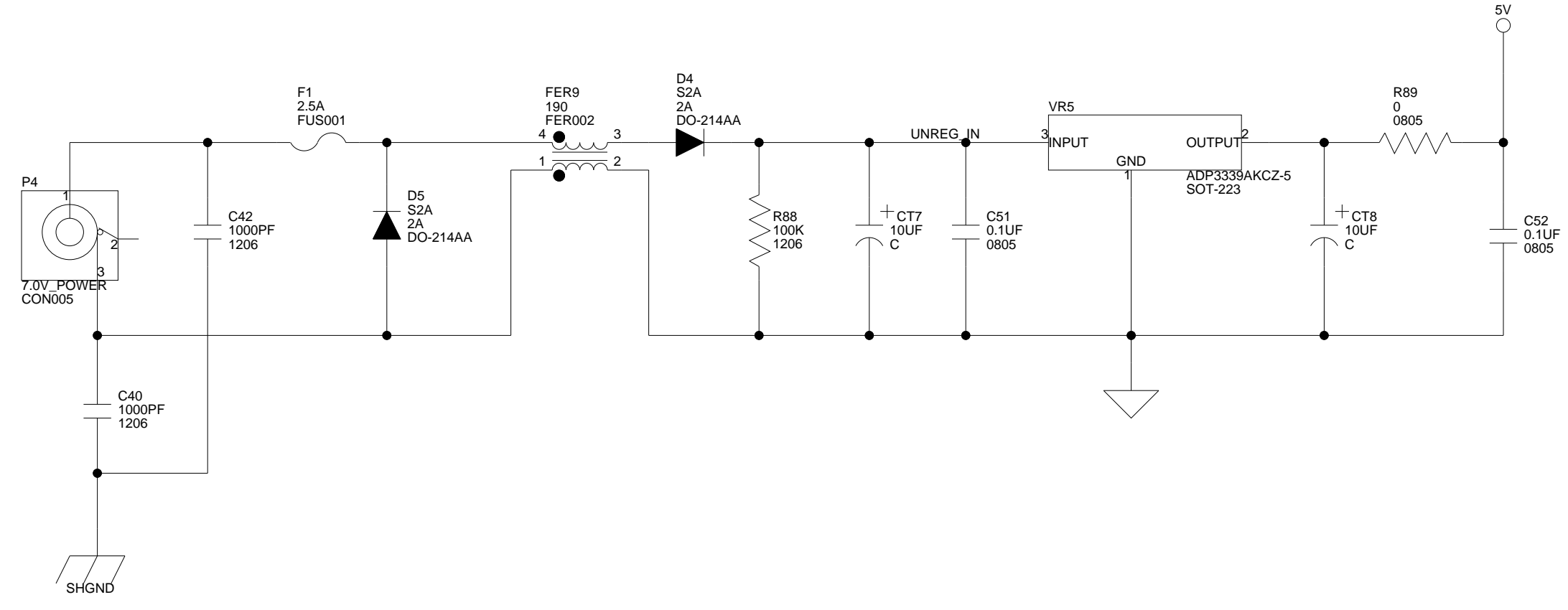

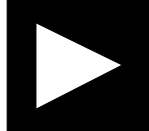
 <b>ANALOG DEVICES</b>		20 Cotton Road Nashua, NH 03063 PH: 1-800-ANALOGD	
		<b>Title</b> ADSP-21160 EZ-KIT LITE <b>POWER</b>	
<b>Size</b> C	<b>Board No.</b> A0164-2001	<b>Rev</b> 2.0	
<b>Date</b> 10-6-2006_14:30	<b>Sheet</b> 7 of 8		

A

B

C

D

1

1

2

2

3

3

4

4

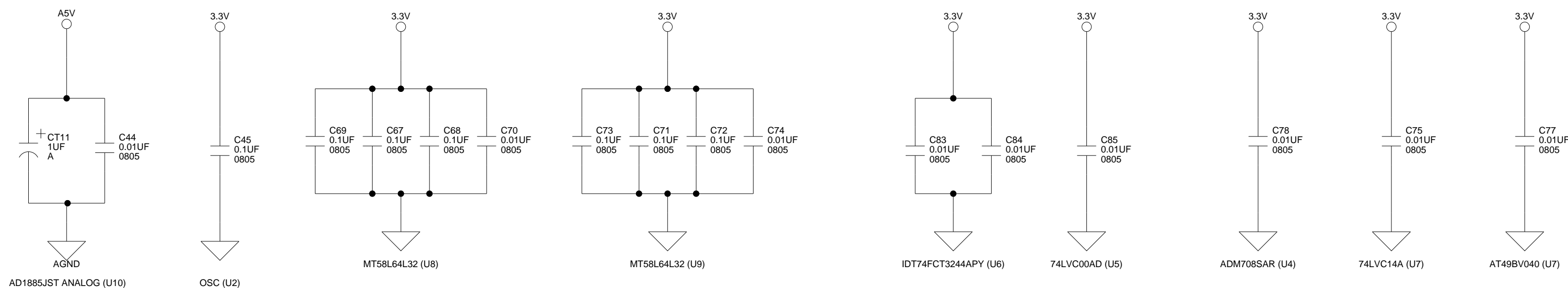
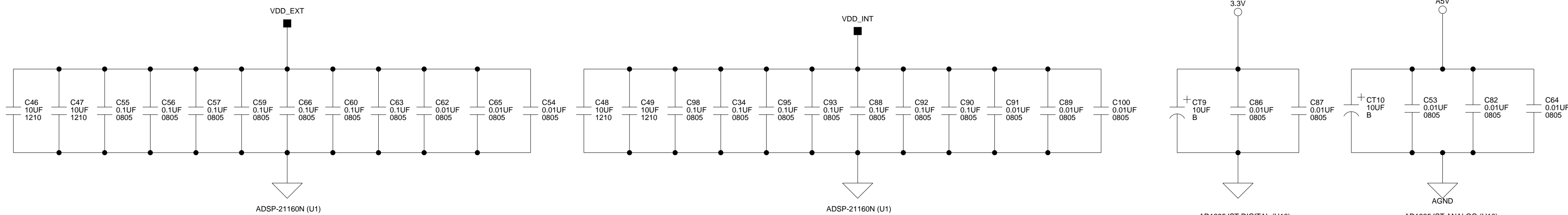

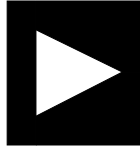
 <b>ANALOG DEVICES</b> 20 Cotton Road Nashua, NH 03063 PH: 1-800-ANALOGD		<b>Title</b> ADSP-21160 EZ-KIT LITE BYPASS CAPS	
		<b>Size</b> C	<b>Board No.</b> A0164-2001
<b>Date</b> 8-24-2006_9:42		<b>Sheet</b> 8 of 8	

# I INDEX

## A

AD1881A CAD and DAC  
  audio input channels, 2-4, 2-6  
  reset pin (FLAG3), 1-9, 2-4  
ADDRESS31-0 pins, 2-4  
architecture, of this EZ-KIT Lite, 2-2  
audio  
  connectors (J4-5), 2-4, 2-6, 2-14  
  input select jumper (JP1), 2-6  
  interface, x, 2-4

## B

bill of materials, A-1  
-BMS memory select pins, 1-7, 1-8, 2-3, 2-7  
board schematic (ADSP-21160), B-1  
boot mode select switch (SW1), 2-7

## C

configuration, of this EZ-KIT Lite, 1-3  
connectors  
  diagram of locations, 1-3, 2-11  
  J4-5 (audio), 2-4, 2-6, 2-14  
  P11 (SPORT0), 2-4, 2-15  
  P1 (expansion), 2-3, 2-4, 2-12  
  P2 (expansion), 1-9, 1-10, 2-3, 2-4, 2-12  
  P3 (expansion), 2-3, 2-4, 2-12  
  P4 (power), 1-4, 2-12  
  P5-6 (link port), 2-13  
  ZJ1 (USB), 1-4, 2-13  
  ZP4 (JTAG), 2-5, 2-14

contents, of this EZ-KIT Lite package, 1-2  
core  
  frequency, 2-3  
  voltage, 2-2, 2-16  
current limits, 2-5  
current measurements, 2-16  
customer support, xiv

## D

default configuration, of this EZ-KIT Lite, 1-3

## E

EBOOT pins, 2-7  
example programs, 1-10  
expansion interface, 2-3, 2-4, 2-12  
external  
  memory, 1-8  
  memory boot mode (no-boot), 2-7  
  oscillators, 2-3  
  ports, 1-7, 2-3

## F

features, of this EZ-KIT Lite, x  
FLAG3-0 pins, 1-9, 2-4, 2-9  
FLAG system registers, 1-9  
flash  
  memory, xi, 1-7, 1-8, 2-3  
  memory boot mode, 2-7  
frequency, 2-3

# INDEX

## G

general-purpose IO pins, [xi](#), [1-9](#), [2-9](#)  
global interrupts, [1-9](#)

## H

host processor boot mode, [2-7](#)

## I

installation, of this EZ-KIT Lite, [1-5](#)  
internal memory (SRAM), [1-8](#)  
interrupts  
    push buttons (SW3-5), [xi](#), [1-10](#), [2-10](#)  
    request pins (IRQ0-2), [1-9](#), [1-10](#), [2-4](#)

## J

JP1 (audio input select) jumper, [1-3](#), [2-4](#), [2-6](#)

## JTAG

connector (ZP4), [2-5](#), [2-14](#)  
emulation port, [2-5](#)

## L

LBOOT pins, [2-7](#)

## LEDs

diagram of locations, [1-3](#), [2-8](#)  
LED2-4 (FLAG0-2), [1-9](#), [2-9](#)  
LED6 (power), [1-4](#), [2-9](#)  
LED7 (reset), [1-4](#), [2-8](#)  
ZLED3 (USB monitor), [1-5](#), [2-9](#)

license restrictions, [1-7](#)

LINE IN stereo input channel, [2-4](#), [2-6](#)

## link port

boot mode, [2-7](#)  
connectors, [2-13](#)

## M

measurements, of this EZ-KIT Lite, [2-16](#)

## memory

map, of this EZ-KIT Lite, [1-7](#)  
    select pins, *See* [-BMS](#), [-MS1-0](#)  
MIC1 mono input channel, [2-4](#), [2-6](#)  
MODE2 register, [1-9](#)  
-MS1-0 memory select pins, [1-7](#), [1-8](#), [2-3](#)  
MSIZE bits, [1-8](#)  
multiprocessor memory space, [1-8](#)

## N

no-boot mode, [2-7](#)  
notation conventions, [xxi](#)

## O

oscillators, [2-3](#)

## P

package contents, [1-2](#)  
peripheral interface, [2-2](#)  
power  
    connector (P4), [1-4](#), [2-12](#)  
    LED (LED6), [1-4](#), [2-9](#)  
    supply, [2-12](#), [2-16](#)  
push buttons  
    diagram of locations, [2-8](#)  
    SW2 (reset), [2-10](#)  
    SW3-5 (interrupts), [1-10](#), [2-10](#)

## R

R6-7 (current measurements) resistors, [2-16](#)  
RCLK0 pins, [2-4](#)  
reset  
    LED (LED7), [2-8](#)  
    push button (SW2), [2-10](#)  
restrictions, of the license, [1-7](#)



**S**

SBSRAM memory, [1-7](#), [2-3](#)  
schematic, of ADSP-21160 EZ-KIT Lite, [B-1](#)  
specifications, of this EZ-KIT Lite, [2-16](#)  
SPORT0  
    audio interface, [2-4](#)  
    connector (P11), [2-4](#), [2-15](#)  
SRAM memory, [1-7](#)  
startup, of this EZ-KIT Lite, [1-5](#)  
stereo  
    connectors (J4-5), [2-4](#), [2-6](#), [2-14](#)  
    input channel (LINE IN), [2-4](#), [2-6](#)  
SW1 (boot mode select) switch, [2-7](#)  
SW2 (reset) push button, [2-10](#)  
SW3-5 (interrupt) push buttons, [1-10](#), [2-10](#)  
SYSCON register, [1-8](#)  
system architecture, [2-2](#)

**T**

TCLK0 pins, [2-4](#)  
TIMEXP pins, [2-4](#)

**U**

USB  
    cable, [1-3](#)  
    connector (ZJ1), [2-13](#)  
    interface, [2-5](#), [2-14](#)  
    monitor LED (ZLED3), [2-9](#)

**V**

VDD\_EXT voltage plane, [2-16](#)  
VDD\_INT voltage plane, [2-16](#)  
VisualDSP++  
    documentation, [xix](#)  
    online Help, [xix](#)  
voltage planes, [2-16](#)

# INDEX